

Montageanleitung

Ⓒ mounting instruction Ⓕ Notice de montage Ⓖ Instrukcja montażu
Ⓔ Instrucciones de montaje Ⓘ Istruzioni di montaggio

DLE 85/ 90/ 110/ 175/ 245

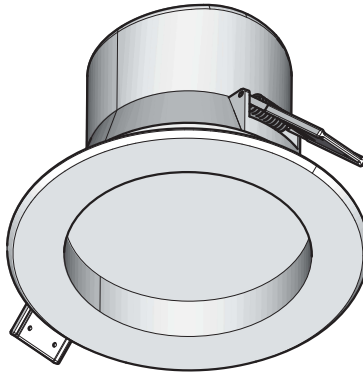

RIDI Leuchten GmbH
• Hauptstrasse 31 - 33 • D-72417 Jungingen
• Tel. 07477/872-0 • Fax 07477/872-48
• kontakt@ridi-group.de • www.ridi-group.com



- D** Für die Installation und für den Betrieb der Leuchten sind die nationalen Sicherheitsvorschriften zu beachten.
- GB** Please note national safety instructions for installation and operation of this luminaire.
- F** Pour l'installation et le fonctionnement des luminaires il est impératif de respecter les normes nationales de sécurité en vigueur.
- PL** W celu prawidłowej instalacji i poprawnego działania oprawy należy przestrzegać krajowych przepisów bezpieczeństwa.
- E** Para la instalación y la puesta en funcionamiento de las luminarias deben observarse las normas nacionales de seguridad.
- I** Per l'installazione e il funzionamento delle lampade si fa riferimento alle normative di sicurezza nazionali.

- D** Die Lichtquelle dieser Leuchte ist nicht ersetzbar, wenn die Lichtquelle ihr Lebensdauerende erreicht hat, ist die gesamte Leuchte zu ersetzen.
- GB** The light source of this luminaire is not replaceable. When light source has reached end of life-time the complete luminaire has to be replaced.
- F** La source lumineuse de ce luminaire n'est pas remplaçable. Quand la source lumineuse aura atteint la limite de sa durée de vie, le luminaire complet doit être remplacé.
- PL** Nie ma możliwości wymiany źródła światła w tej oprawie oświetleniowej, po zakończeniu żywotności źródła światła, należy wymienić całą oprawę oświetleniową.
- E** La fuente luminica de esta luminaria no se puede sustituir. Cuando la fuente luminica ha alcanzado el final de su vida útil, hay que sustituir toda la luminaria.
- I** La sorgente luminosa di tale lampada può essere sostituita solo dal produttore o da un tecnico di assistenza da questi designato oppure da personale dotato di qualifica equivalente.

| Typ | øDE | min.HE |
|------------|---------|--------|
| DLE 85...* | 68-75 | 94 |
| DLE 90... | 68-80 | 82 |
| DLE 110... | 90-102 | 92 |
| DLE 175... | 145-155 | 100 |
| DLE 245... | 210-224 | 120 |

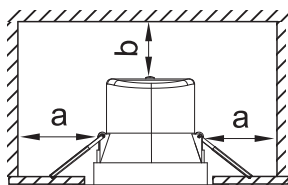
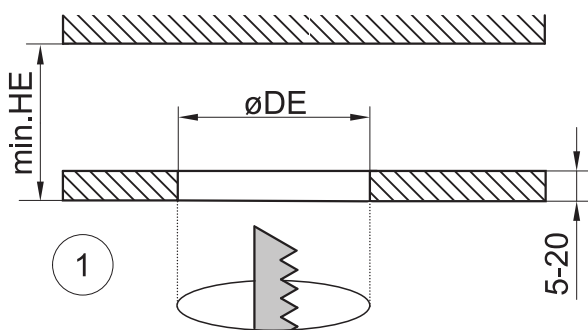
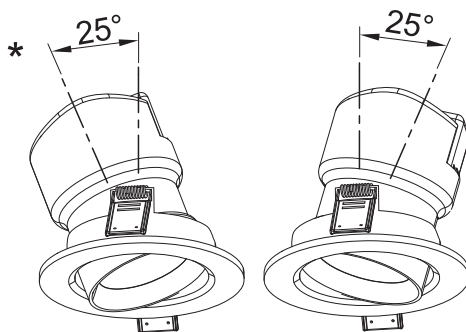

$a_{min} = 75 \text{ mm}$
 $b_{min} = 20 \text{ mm}$

Keine Isolierung
 no insulation
 Pas d'isolation
 bez izolacji
 ningün aislamiento

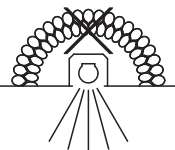

RIDI

AC 230-240V/50-60Hz

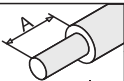

|  | mm ² | A |
|---|-----------------|---|
| sol. | 0,75-1,5 | 8 |
| DLE 85/175/245 * | 0,5-1,5 | |
| DLE 90/110 * | 0,5-1,5 | |

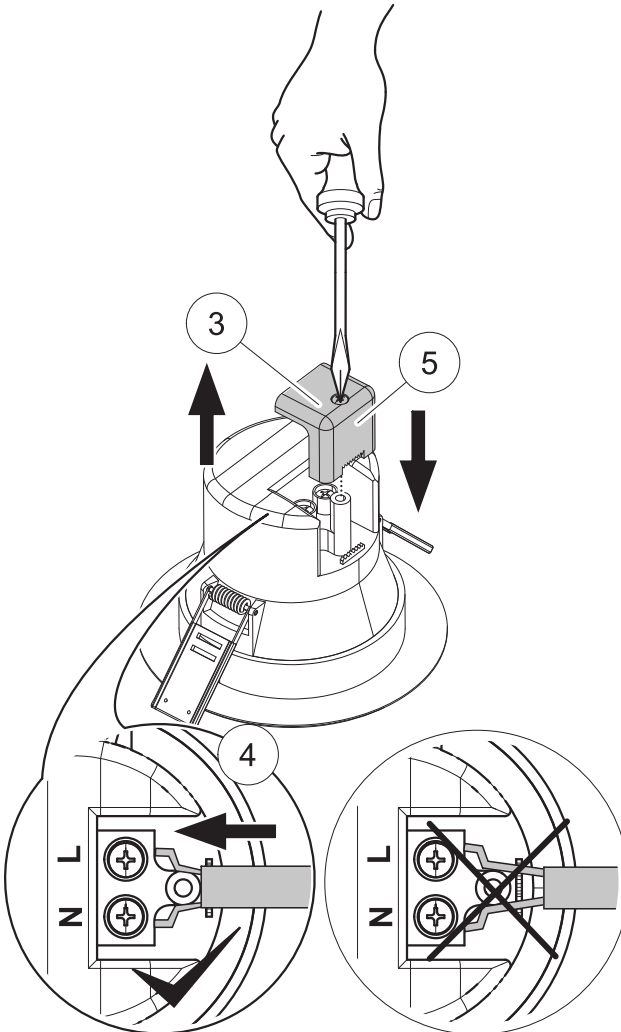
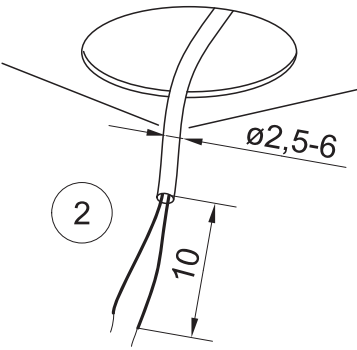
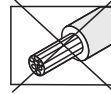

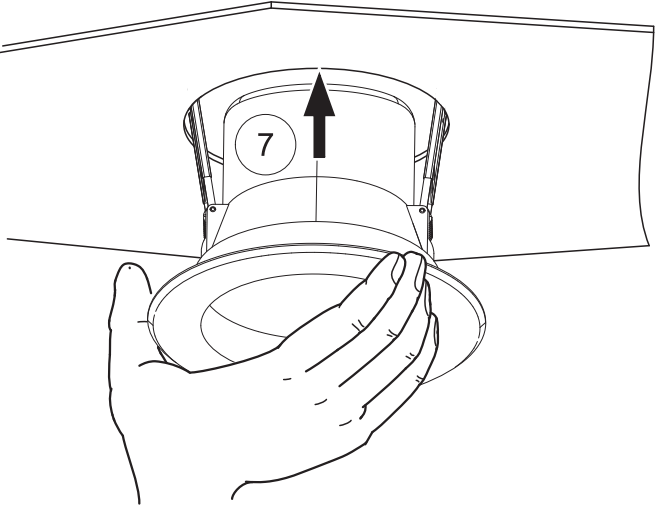
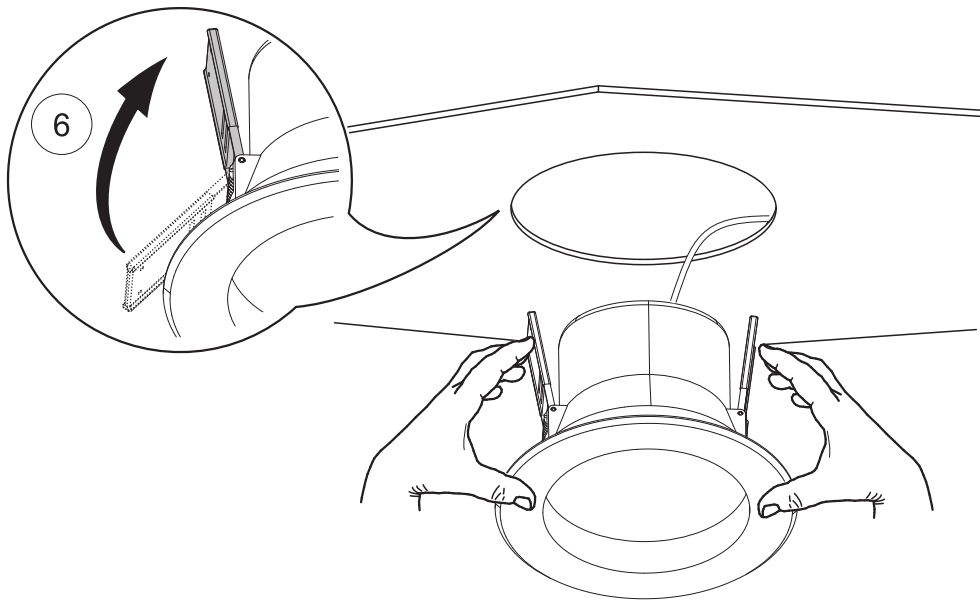

DLE 85...

