

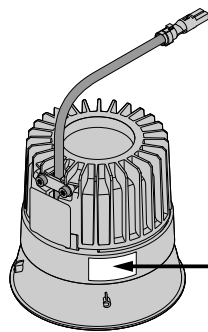

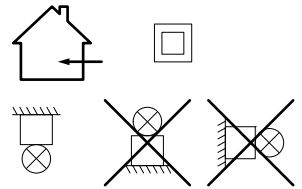

Typ-Nr. E14487

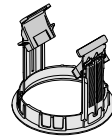
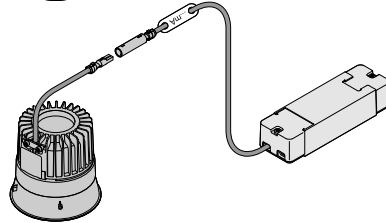
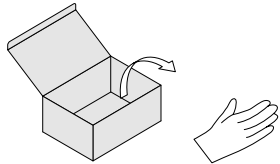
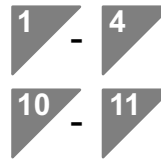
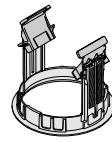
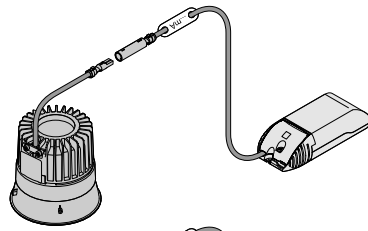
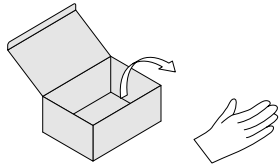

ZUMTOBEL

Mod -----  
 Ser -----  
 Typ -----

.....W LED (.....mA)  
220-240V 0/50/60Hz

i

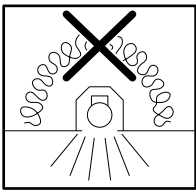
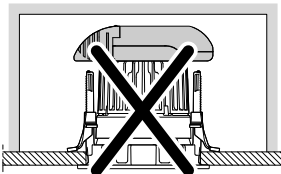

**DE** Leuchte darf nicht mit Wärmedämmung abgedeckt werden.

**GB** Luminaire not suitable for covering with thermally insulating material.

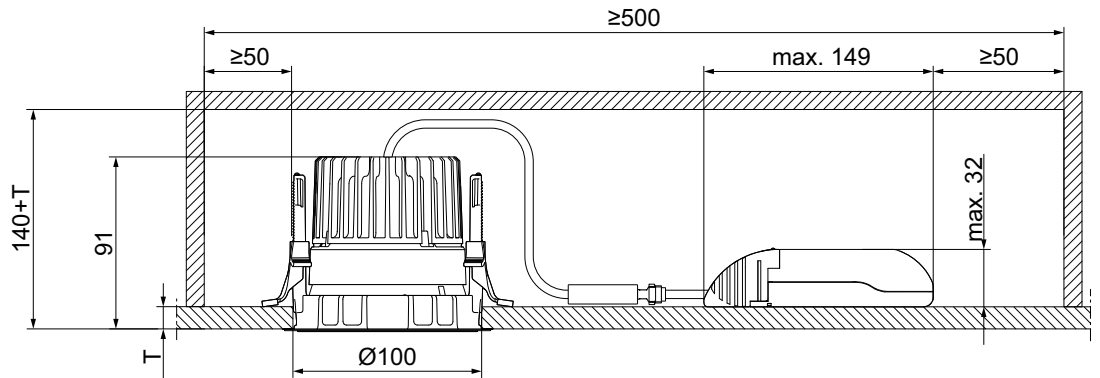

T=1-40

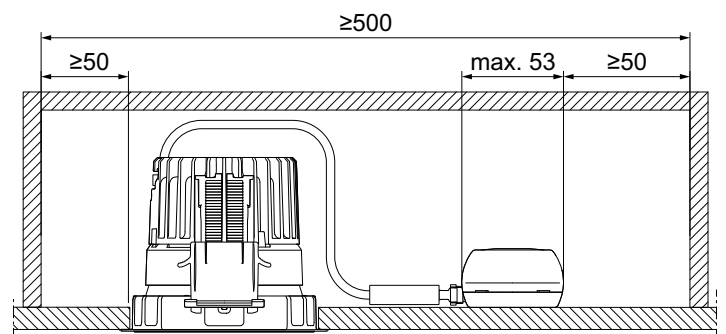

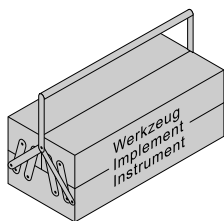
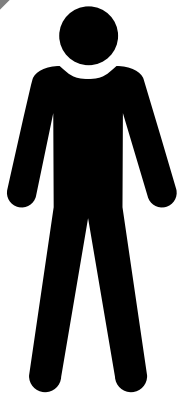

**DE** Die Montage und Inbetriebnahme darf nur von autorisiertem Fachpersonal durchgeführt werden.

**NL** De montage en inbedrijfstelling mogen enkel door erkend vakpersoneel worden uitgevoerd.

**GB** Installation and commissioning may only be carried out by authorized specialists.

**NO/SE** Monteringen och idrifttagandet får endast företas av auktoriserad fackpersonal.

**FR** L'installation et la mise en service doivent obligatoirement être effectuées par des techniciens.

**FI** Asennuksen ja käyttöönoton saa tehdä vain auktorisoitu ammattihenkilöstö.

**IT** Montaggio ed avviamento devono essere eseguiti solo da personale specializzato.

**ES** El montaje y la puesta en marcha sólo puede ser realizado por personal especializado autorizado.

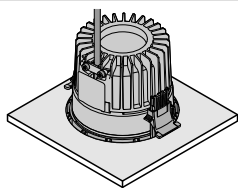

**DE** Die Leuchte dient ausschließlich der Beleuchtung und ist entsprechend den nationalen Errichtungsbestimmungen zu installieren. Eine andere Nutzung oder ein anderer Einbau gilt als „nicht bestimmungsgemäß“.

**GB** The luminaire is used exclusively for lighting and is to be installed in accordance with the national installation regulations. Any other use or installation is regarded as "not according to instructions".

**FR** Le luminaire sert uniquement à l'éclairage et doit être installé conformément aux prescriptions nationales en matière d'installation. Toute autre utilisation ou installation est considérée comme "non conforme".

**NO/SE** Armaturen är uteslutande avsedd för belysning och ska installeras i enlighet med de nationella installationsbestämmelserna. All annan användning eller montering gäller som "icke ändamålsenlig".

**IT** L'apparecchio è destinato esclusivamente all'illuminazione e va installato in conformità alle leggi nazionali in vigore. Un altro impiego o un diverso tipo di montaggio non è considerato conforme alle disposizioni.

**FI** Valaisin on tarkoitettu ainoastaan valaistuskäyttöön, ja se on asennettava kansallisten määräysten mukaan. Muu käyttö tai muu asennus katsotaan sopimuksenvastaiseksi käytöksi.

**NL** De lamp dient uitsluitend voor de verlichting en dient conform de nationale bouwbeplanning te worden geïnstalleerd. Een ander gebruik of een andere inbouw is niet conform.

**ES** La lámpara está destinada exclusivamente a la iluminación y debe ser instalada de acuerdo con las pertinentes normas nacionales. Cualquiera otro uso o instalación no se considerará "previsto por la norma".

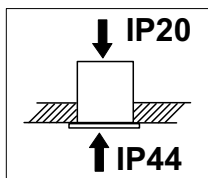

**DE** Voraussetzung für die Schutzart IP 44 der Leuchte ist die Installation in einer geschlossenen Decke! Die Schutzart IP 44 gilt nur von der Raumseite her.

**GB** The luminaire is protection type IP 44, only when being installed in an enclosed ceiling! Protection type IP 44 does not apply in the ceiling void itself.

**FR** L'installation dans un plafond fermé est nécessaire pour qu'une réalisation soit IP 44. La protection IP 44 ne joue que par rapport à la pièce.

**NO/SE** Armaturen har kapslingsgrad IP 44 bare når den er bygget inn i tett undertak. IP 44 gjelder bare nedenfra (fra rommet).

**IT** La premessa per il tipo di protezione IP 44 dei modelli è l'installazione in uno spazio chiuso! Il sistema di protezione IP 44 riguarda solamente gli spazi laterali dai quali fuoriesce il fascio di luce.

**FI** Kotelointiluokka IP 44 pätee vain umpikattoon asennetulle valaisimelle. Kotelointiluokka IP 44 pätee vain huoneen puolelta.

**NL** Voorwaarde voor de classificatie IP 44 van het armatuur is, de installatie in een gesloten plafond. De classificatie IP 44 geldt alleen voor de ruimtezijde

**ES** La luminaria equipada cumple con la protección IP 44 cuando se encuentra instalada en un techo cerrado. La protección IP 44 concierne únicamente la zona de la luminaria vista desde el interior del local.



**DE** Verwendung nur in Verbindung mit PANOS INF Leuchte.

**FR** Seul en combinaison avec luminaire PANOS INF.

**GB** Only use with PANOS INF luminaire.

**IT** Solamente in combinazione con apparecchio PANOS INF.

**NL** Enkel in combinatie met PANOS INF armatuur.

**NO/SE** Kun i forbindelse med PANOS INF - belysningsarmatur.

**FI** Ainoastaan PANOS INF -valaisimen yhteydessä.

**ES** Solo en combinación con luminaria PANOS INF.

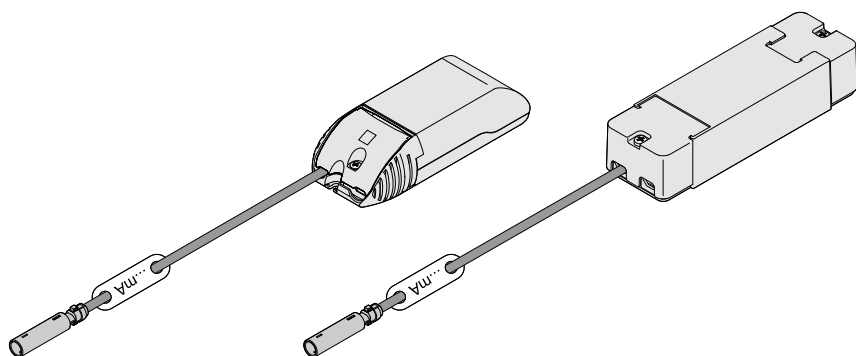

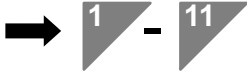

**FR** **Attention!** Toujours travailler sans tension lors du câblage et de l'installation des luminaires et unités d'alimentation. Le non-respect de cette consigne peut entraîner la destruction des modules à LED.

**NO/SE** **OBS!** Koble alltid fra strømmen ved kabling og installasjon av lampene og strømforsyningsenhetene. LED-modulene kan ødelegges dersom dette ignoreres.

**DE** **Achtung!** Während der Verdrahtung und Installation der Leuchten und Versorgungsgeräte immer spannungslos arbeiten. Nichtbeachtung kann zur Zerstörung der LED- Module führen.

**IT** **Attenzione!** Lavorare sempre in assenza di tensione mentre si cablano e si installano gli apparecchi e le unità di alimentazione. In caso contrario i moduli LED possono andare distrutti!

**FI** **Huom!** Valaisimien ja syöttölaitteiden kytkemisen ja asentamisen aikana on aina työskenneltävä jännitteettömästi. Muutoin led-moduulit voivat tuhoutua.

**GB** **Caution!** Make sure that the luminaires and power supply units are always disconnected from the mains supply during wiring and installation work. Otherwise, the LED modules may be destroyed.

**NL** **Opgelet!** Tijdens het bedraden en installeren van de armaturen en voedingsapparaten altijd zonder spanning werken. Bij niet-naleving hiervan kunnen de LED-modules ernstig worden beschadigd.

**ES** **Atención** Siempre mantenga desconectada la tensión al realizar las tareas de cableado y de instalación de las luminarias y dispositivos de alimentación. De lo contrario podría destruirse el módulo LED.



60800313

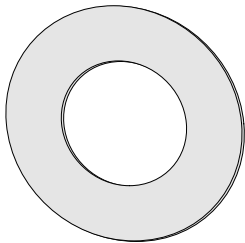

**DE** Bei dünnem oder weichem Deckenmaterial empfiehlt sich die Verwendung des Deckenverstärkungsringes zur Vergrößerung der Auflagefläche!

**NL** Bij dun of zacht plafondmateriaal is het gebruik van de plafondverstevigende ring ter vergroting van het draagvlak aanbevelenswaardig!!

**GB** With thin or soft ceiling material it is recommended that ceiling reinforcing rings should be used to enlarge the bearing surface.

**NO/SE** For svakt eller mykt tildekkingsmateriale anbefaler vi bruk av forsterkingsringer for å øke anleggsflaten!

**FR** On recommande l'utilisation de la bague de renfort de plafond pour agrandir la surface portante lorsque le matériau du plafond est mince ou souple.

**FI** Kattomateriaalin ollessa ohutta tai pehmeää on katonvahvistusrenkaan käyttö suositeltavaa asetuspinnan suurentamiseksi.

**IT** Con materiale coprente sottile o flessibile è consigliato l'impiego dell'anello di rinforzo della copertura per ingrandire la superficie d'appoggio!

**ES** En caso de material para cielorrasos fino o blando, se recomienda utilizar el aro de refuerzo de cielorrasos para agrandar la superficie de apoyo.

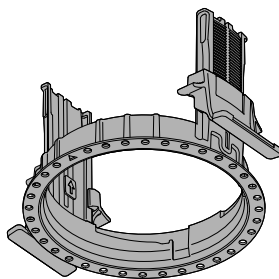

Anleitung / Instruction  
06979728

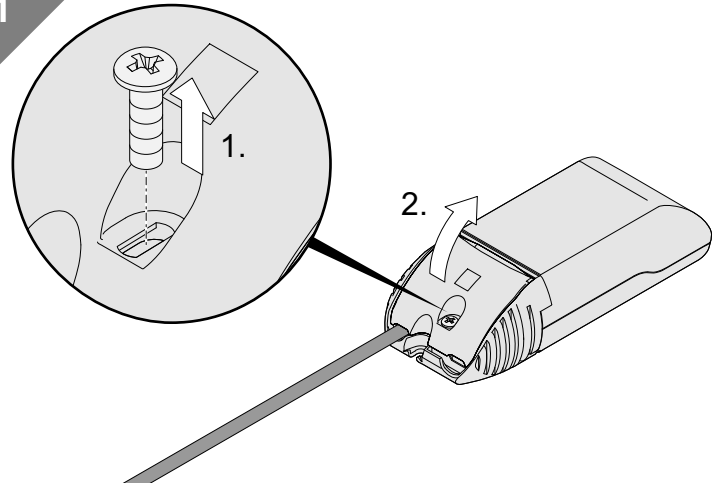

switchDIM

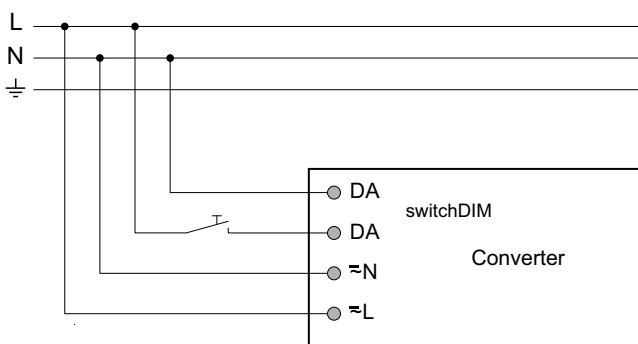

2

~~Durchschleifen - Looping-in (feed through)  
 Câblage traversant (le luminaire)  
 Cablaggio passante - Doorlussen  
 Överkoppling - Keyless - Enlazado~~

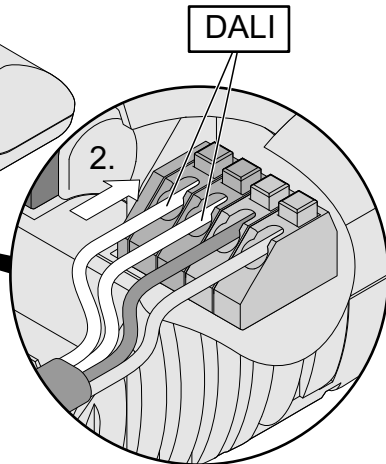
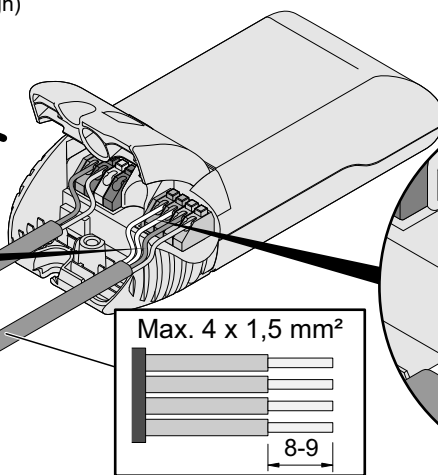
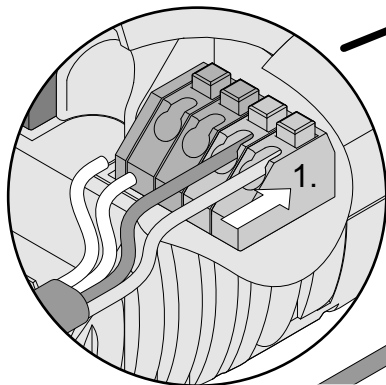
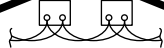

Max. 4 x 1,5 mm<sup>2</sup>

8-9

3

0,8 Nm

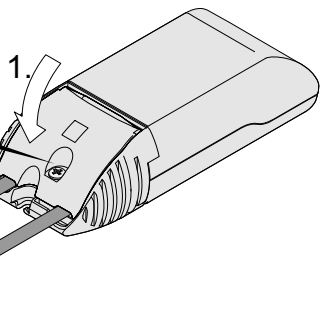
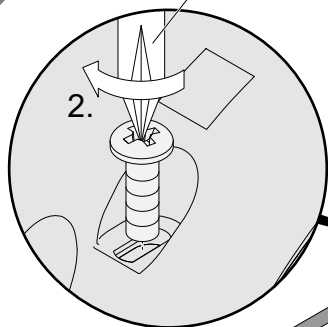

4

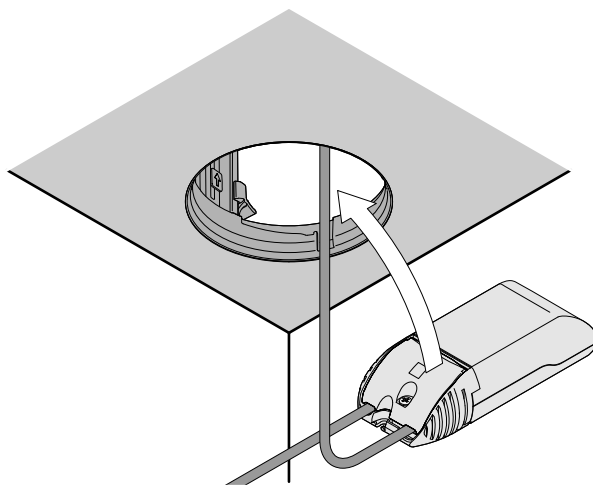

5

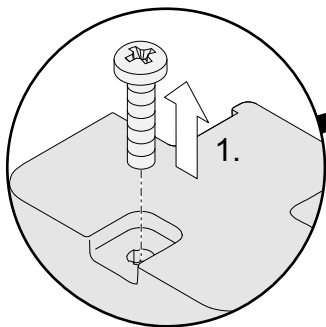

2.

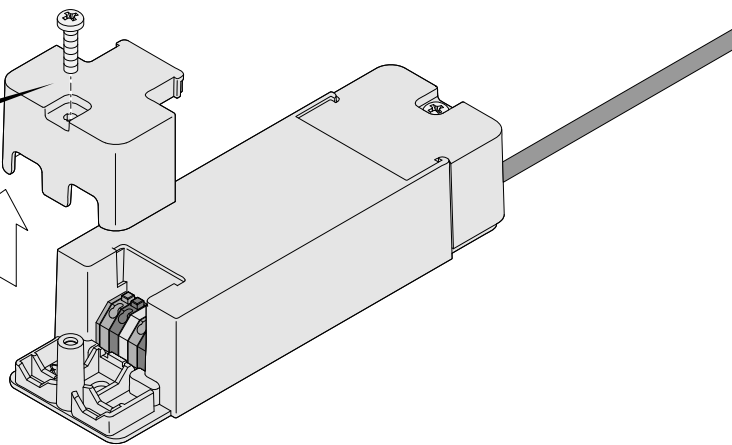

6

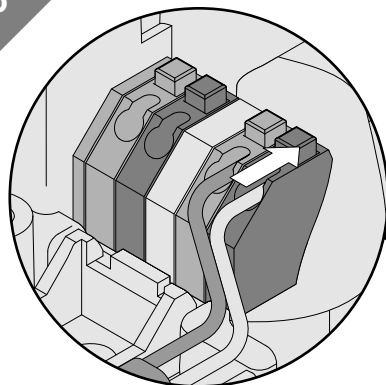

Max. 2 x 1,5 mm<sup>2</sup>

8-9

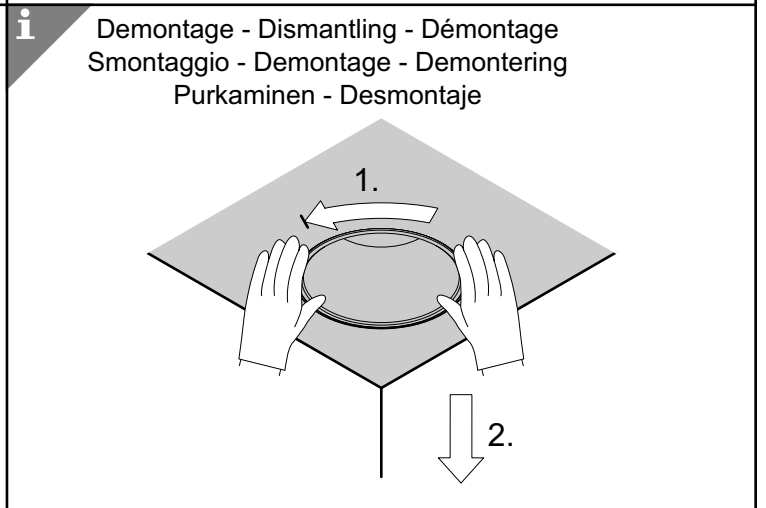
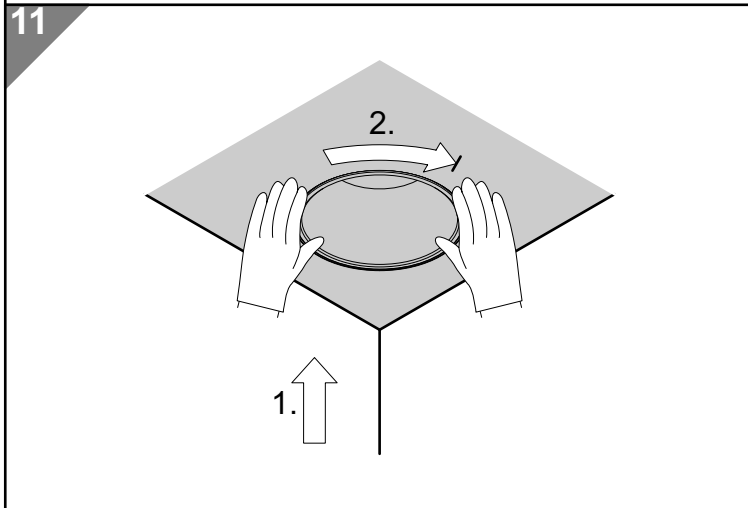
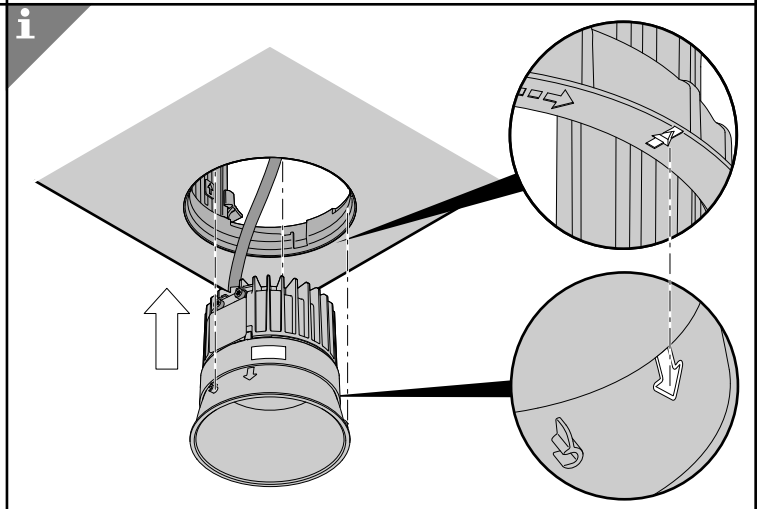
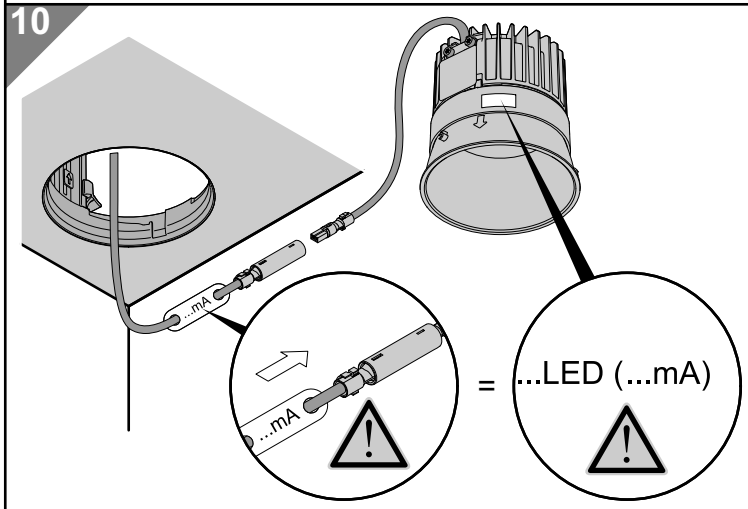
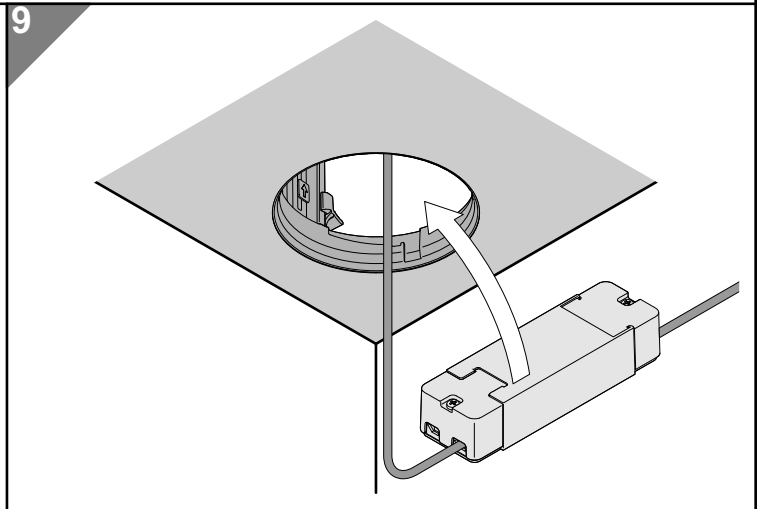
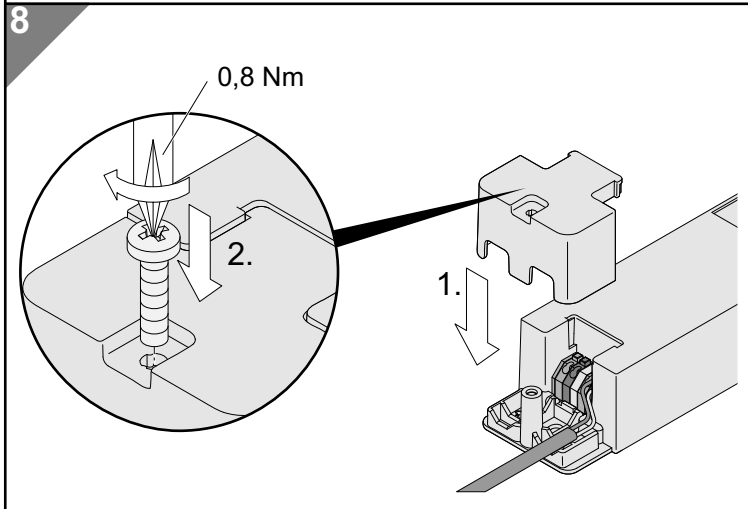
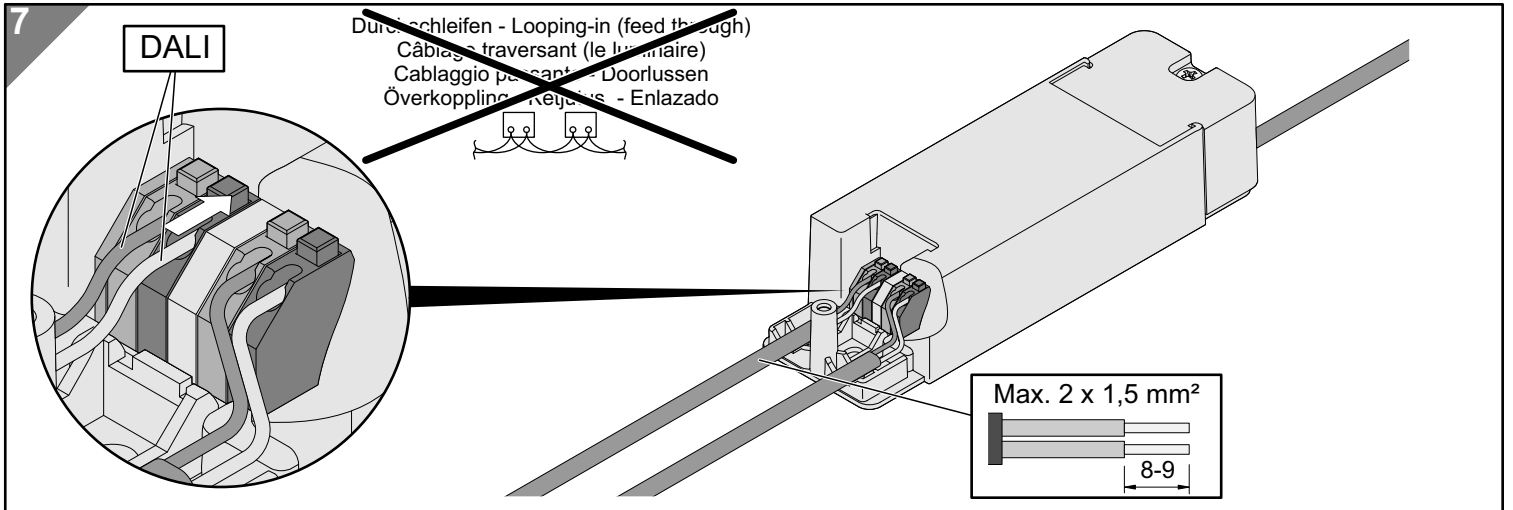

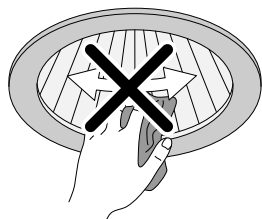
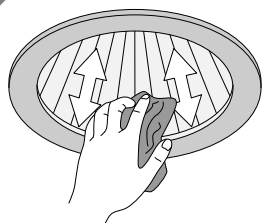

**DE** Reflektorreinigung  
**GB** Reflector cleaning  
**FR** Nettoyage du réflecteur  
**IT** Pulizia di riflettori  
**NL** Reflectorreininging  
**NO/SE** Reflektorrengöring  
**FI** Reflektorin puhdistus  
**ES** Limpieza del reflector



60 800 118



**DE** Reflektorreinigungstuch  
**GB** Reflector cleaning cloth  
**FR** Chiffon de nettoyage du réflecteur  
**IT** Straccio per la pulizia di riflettori  
**NL** Reinigingsdoek voor reflector  
**NO/SE** Reflektorrengöringsduk  
**FI** Reflektorinpuhdistusliina  
**ES** Paño para limpiar el reflector

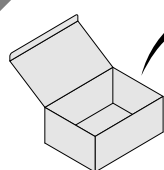

**a**

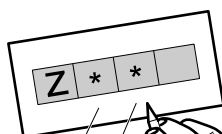

mode of operation: 0/1  
 facilities: A...F

**b**

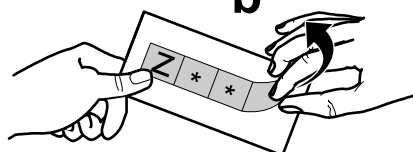

**c**

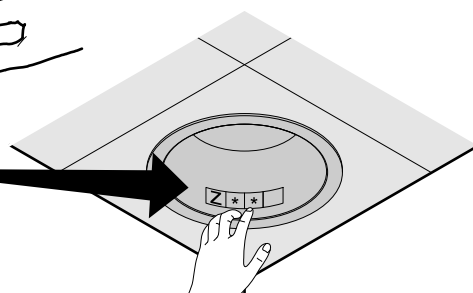

- DE** Leuchten für Notlicht nach EN 60598-2-22. Diese Leuchte ist nur für Anlagen bestimmt, in denen die Steckverbindung vor unbefugtem Trennen geschützt ist.
- GB** Option Emergency Lighting EN 60598-2-22. This luminaire is exclusively intended for systems with a plug-in connection that is protected against unauthorized disconnecting.
- FR** Option Emergency Lighting EN 60598-2-22. Ce luminaire est uniquement destiné aux installations où le connecteur est protégé contre toute déconnexion involontaire.
- IT** Opzione luce di emergenza EN 60598-2-22. Questo apparecchio è destinato unicamente ad impianti in cui non è possibile staccare l'innesto se non dietro autorizzazione.
- NL** Optie Emergency Lighting EN 60598-2-22. Deze armatuur is enkel bedoeld voor installaties waarbij de steekverbinding beschermd is tegen onbedoelde ontkoppeling.
- NO/SE** Option Emergency Lighting EN 60598-2-22. Denna armatur är endast avsedd för anläggningar i vilka stickkontakten inte kan dras ut av obehöriga.
- FI** Lisävaruste hätävalaisin EN 60598-2-22. Tämä valaisin on tarkoitettu vain sellaisille laitteistoille, joissa pistoliitäntä on suojattu tahattomalta katkaisulta.
- ES** Opción Emergency Lighting EN 60598-2-22. Esta luminaria está destinada únicamente a sistemas en los que el conector enchufable está protegido contra su separación imprevista.

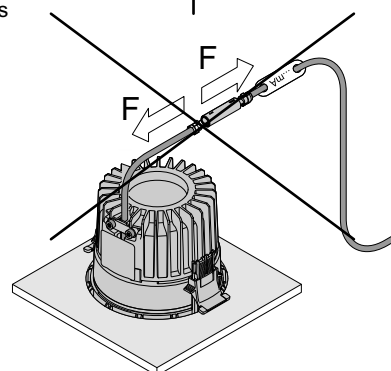

Technische Änderungen vorbehalten. - Specifications subject to change without notice. - Modifications techniques sans préavis.  
 Modifiche tecniche senza preavviso. - Technische wijzigingen voorbehouden.  
 Med forbehold om tekniske endringer. - Oikeudet teknisiin muutoksiin pidätetään. - Modificaciones técnicas sin preaviso.