

Typ-Nr. E14649

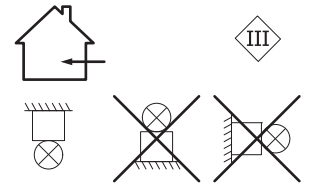

600mA DC

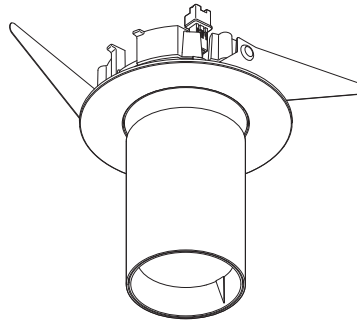
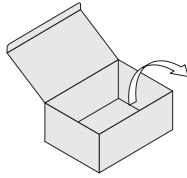
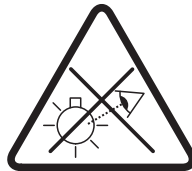
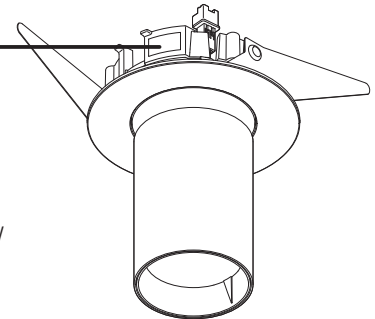

**DE** Nicht in die Lichtquelle/ Leuchte starren.

**EN** Do not stare at the light source.

**i**

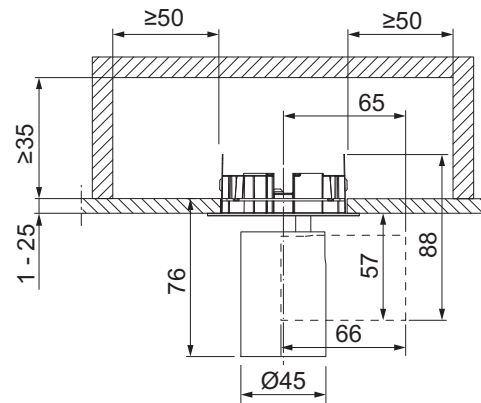
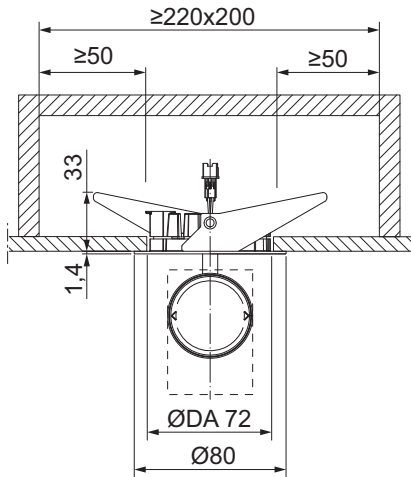

**!**

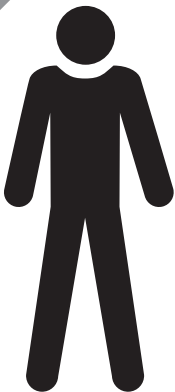

**DE** Die Montage und Inbetriebnahme darf nur von autorisiertem Fachpersonal durchgeführt werden.

**NL** De montage en inbedrijfstelling mogen enkel door erkend vakpersoneel worden uitgevoerd.

**EN** Installation and commissioning may only be carried out by authorized specialists.

**SV** Monteringen och idrifttagandet får endast företas av auktoriserad fackpersonal.

**FR** L'installation et la mise en service doivent obligatoirement être effectuées par des techniciens.

**FI** Asennuksen ja käyttöönoton saa tehdä vain auktorisoitu ammattihenkilöstö.

**IT** Montaggio ed avviamento devono essere eseguiti solo da personale specializzato.

**ES** El montaje y la puesta en marcha sólo puede ser realizado por personal especializado autorizado.

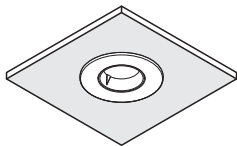

**FR** Le luminaire sert uniquement à l'éclairage et doit être installé conformément aux prescriptions nationales en matière d'installation. Toute autre utilisation ou installation est considérée comme "non conforme".

**SV** Armaturen är uteslutande avsedd för belysning och ska installeras i enlighet med de nationella installationsbestämmelserna. All annan användning eller montering gäller som "icke ändamålsenlig".

**DE** Die Leuchte dient ausschließlich der Beleuchtung und ist entsprechend den nationalen Errichtungsbestimmungen zu installieren. Eine andere Nutzung oder ein anderer Einbau gilt als „nicht bestimmungsgemäß“.

**IT** L'apparecchio è destinato esclusivamente all'illuminazione e va installato in conformità alle leggi nazionali in vigore. Un altro impiego o un diverso tipo di montaggio non è considerato conforme alle disposizioni.

**FI** Valaisin on tarkoitettu ainoastaan valaistuskäyttöön, ja se on asennettava kansallisten määräysten mukaan. Muu käyttö tai muu asennus katsotaan sopimuksenvastaiseksi käytöksi.

**EN** The luminaire is used exclusively for lighting and is to be installed in accordance with the national installation regulations. Any other use or installation is regarded as "not according to instructions".

**NL** De lamp dient uitsluitend voor de verlichting en dient conform de nationale bouwbepalingen te worden geïnstalleerd. Een ander gebruik of een andere inbouw is niet conform.

**ES** La lámpara está destinada exclusivamente a la iluminación y debe ser instalada de acuerdo con las pertinentes normas nacionales. Cualquier otro uso o instalación no se considerará "previsto por la norma".



**FR** **Attention!** Toujours travailler sans tension lors du câblage et de l'installation des luminaires et unités d'alimentation. Le non-respect de cette consigne peut entraîner la destruction des modules à LED.

**SV** **OBS!** Koble alltid fra strømmen ved kabling og installasjon av lampene og strømforsyningsenhetene. LED-modulene kan ødelegges dersom dette ignoreres.

**DE** **Achtung!** Während der Verdrahtung und Installation der Leuchten und Versorgungsgeräte immer spannungslos arbeiten. Nichtbeachtung kann zur Zerstörung der LED-Module führen.

**IT** **Attenzione!** Lavorare sempre in assenza di tensione mentre si cablano e si installano gli apparecchi e le unità di alimentazione. In caso contrario i moduli LED possono andare distrutti!

**FI** **Huom!** Valaisimien ja syöttölaitteiden kytkemisen ja asentamisen aikana on aina työskennettävä jännitteettömästi. Muutoin led-moduulit voivat tuhoutua.

**EN** **Caution!** Make sure that the luminaires and power supply units are always disconnected from the mains supply during wiring and installation work. Otherwise, the LED modules may be destroyed.

**NL** **Opgelet!** Tijdens het bedraden en installeren van de armaturen en voedingsapparaten altijd zonder spanning werken. Bij niet-naleving hiervan kunnen de LED-modules ernstig worden beschadigd.

**ES** **Atención** Siempre mantenga desconectada la tensión al realizar las tareas de cableado y de instalación de las luminarias y dispositivos de alimentación. De lo contrario podría destruirse el módulo LED.

1

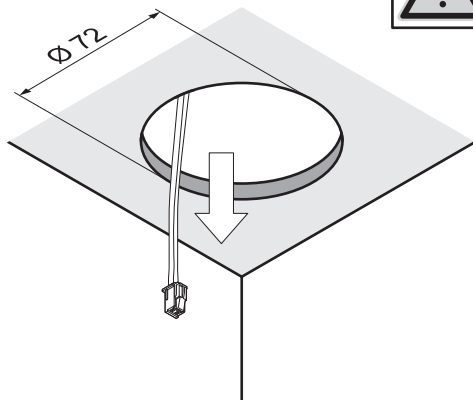

2

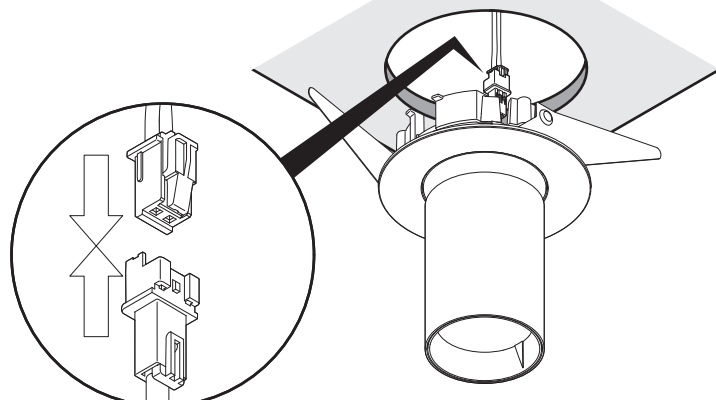

3

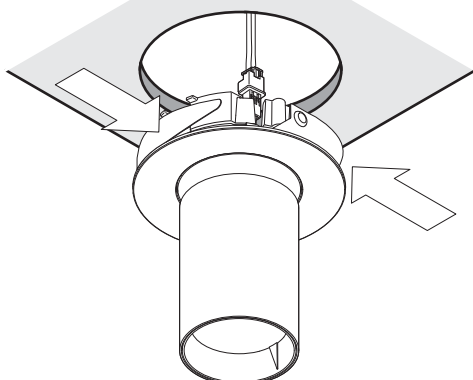

4

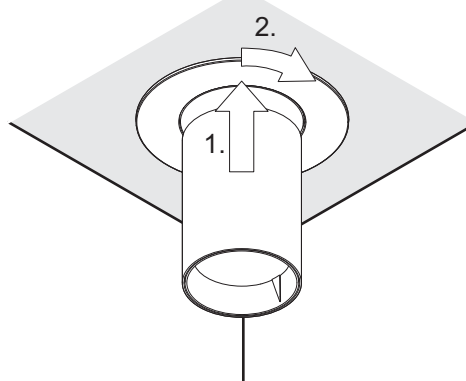

i

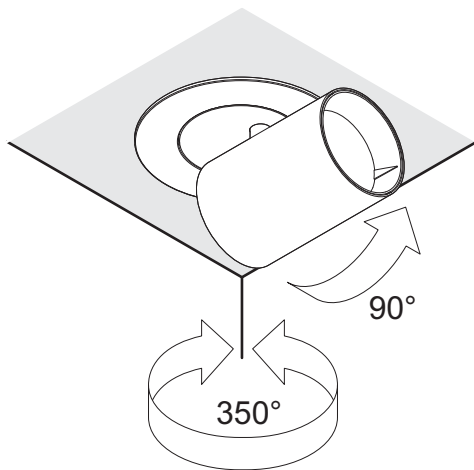

i

Demontage - Dismantling  
 Démontage - Smontaggio  
 Demontage - Demontering  
 Purkaminen - Desmontaje

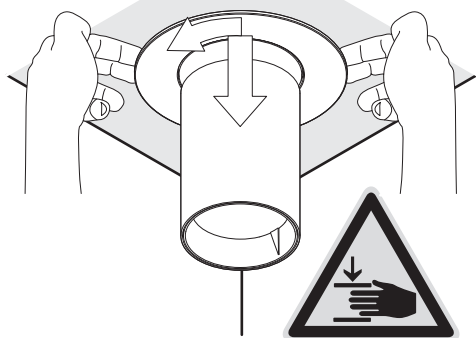

i

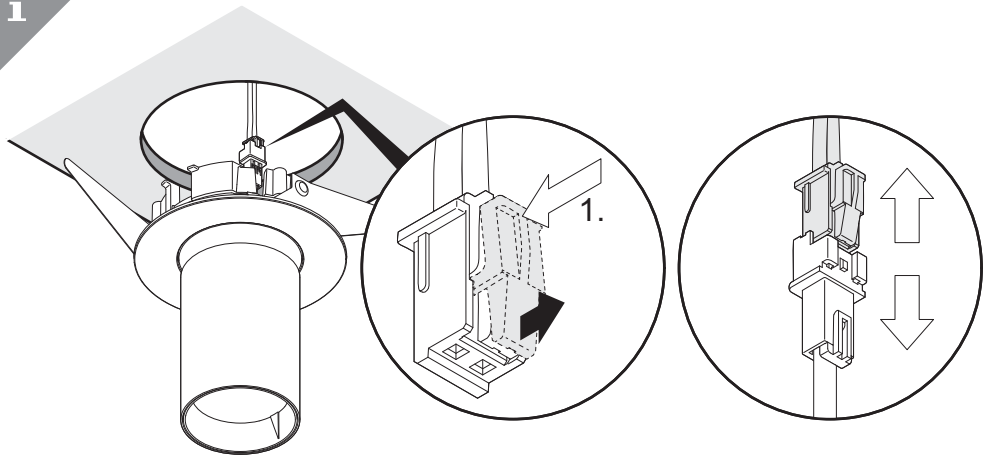

Zubehör - Accessory - Accessoire éventuel - Accessori  
 Toebehoren - Tillbehör - Lisätarvike - Accesorios

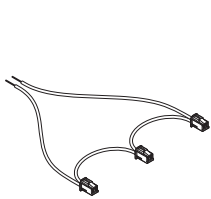

60210870

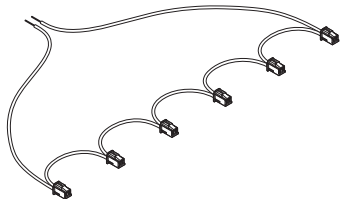

60210871



60210872

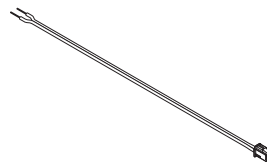

60210873

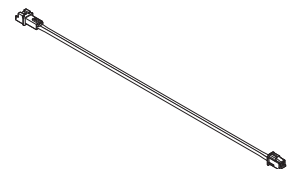

60210874

size M, current 600mA	Betriebsgeräte Nr. / Control gear No. (nur / only Tridonic + TCI)
1x rd (+) — ⊗ — (-) bl	21,23
2x rd (+) — ⊗ — ⊗ — (-) bl	1,4,13,14,16,19,20,21,23
3x rd (+) — ⊗ — ⊗ — ⊗ — (-) bl	14,15,16,17,20,21,23
4x rd (+) — ⊗ — ⊗ — ⊗ — ⊗ — (-) bl	15,17,21,23

Betriebsgerät / Control gear			
No.	Order No.	description	control
1	28000123	LCAI 20W 350mA-900mA ECO SR	DALI
4	28000192	LCI 20W 350mA-900mA TOP SR	fix
13	28000670	DRV TR LCA 17W 700mA 50V D #O4A SR PRE	DALI 4all
14	28000671	LCA 25W 350mA-1050mA one4all SR PRE	DALI 4all
15	28000672	LCA 45W 500mA-1400mA one4all SR PRE	DALI 4all
16	28000675	LCA 25W 350mA-1050mA one4all SC PRE	fix
17	28000676	LCA 45W 500mA-1400mA one4all SC PRE	DALI 4all
19	28000699	DRV TR LC 17W 700mA 50V F #flexC SR EXC	r2m
20	28000700	DRV TR LC 25W 1.05A 50V F #flexC SR EXC	r2m
21	60010043	SUP2S/M/L CONV 36W DALI300-1000MA 220-240V	r2m
23	60010041	SUP2S/M CONV 30W DALI250-700MA 220-240V	DALI

**FR** Les appareillages doivent convenir pour les modules LED et être en conformité avec la norme EN 61347-2-13. SELV U =< 60V.

**SV** Styringsenheter må være egnet til LED-moduler og være i samsvar med standard EN 61347-2-13. SELV U =< 60V.

**DE** Betriebsgeräte müssen für LED-Module geeignet sein und der Norm EN 61347-2-13 entsprechen. SELV U =< 60V.

**IT** Gli alimentatori devono essere adatti ai moduli LED e conformi alla normativa EN 61347-2-13. SELV U =< 60V.

**FI** Käyttölaitteiden on oltava led-moduuleille sopivia ja täytettävä standardin EN 61347-2-13 vaatimukset. SELV U =< 60V.

**EN** Control gear must be suitable for LED modules and comply with the EN 61347-2-13 standard. SELV U =< 60V.

**NL** Bedrijfsapparaten moeten geschikt zijn voor LED-modules en voldoen aan de norm EN 61347-2-13. SELV U =< 60V.

**ES** Los aparatos de servicio deben ser apropiados para los módulos LED y cumplir la norma EN 61347-2-13. SELV U =< 60V.

Technische Änderungen vorbehalten. - Specifications subject to change without notice. - Modifications techniques sans préavis.  
Modifiche tecniche senza preavviso. - Technische wijzigingen voorbehouden.  
Med forbehold om tekniske endringer. - Oikeudet teknisiin muutoksiin pidätetään. - Modificaciones técnicas sin preaviso.