

EL 303.2/B



Beschreibung

- Stromschienenstrahler in getrennter Bauweise für großflächige Spezialbeleuchtung von Backwaren
- Leuchte 355° drehbar und Lichtkopf 140° schwenkbar
- hohe Wartungsfreundlichkeit
- keine UV- und Wärmestrahlung
- innovatives Wärmemanagement mit formintegrierter Passivkühlung
- speziell gewölbter Reflektor mit Hammerschlagoptik aus Reinstaluminium für sehr hohe Lichtausbeute
- Lichtkopf aus Aluminiumdruckguss
- Gehäuse für Betriebsgerät aus Aluminium
- Schutzglas klar
- 3-Phasen-Stromschienenadapter
- Betriebsgerät (LED-Konverter) integriert

Standardoptionen



Farbe	Artikelnummer	EAN
schwarz	646359	4043544533197
silber	646360	4043544533203
weiß	646361	4043544533210

Sonderoptionen



Lichttechnik / Normen

Leuchtmittel	LED Spot Bakery
Lebensdauer	L90 B50 50.000 h L80 B50 100.000 h L80 B20 50.000 h
Systemleistung	40.0 W
Leuchten-Lichtstrom	4470 lm
Systemeffizienz	111.75 lm/W
Moduleffizienz	142.00 lm/W
UGR 4H/8H 70/50/20	20.5/28.4 (C0/C90)
Abstrahlwinkel	75°
Versorgungsspannung	220 - 240 V / 50 Hz
Schutzklasse	I
Schutzart	IP20

Abmessungen / Gewichte

Länge	215 mm
Breite	117 mm
Höhe	207 mm
Nettogewicht	2.12 kg
Bruttogewicht	2.24 kg

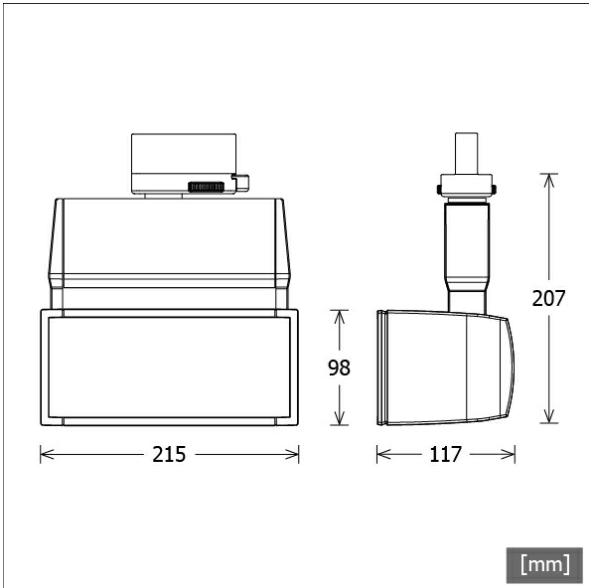

EL 303.2/B

EL 303.2/B

EuroLED 300 | Track-Mounted (1xLED 40W BAKERY 4470lm 75°)

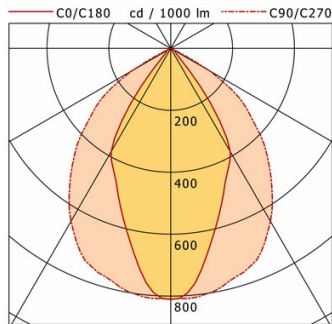

	C0	C90	C180	C270
0°	810	810	810	810
15°	581	771	581	771
30°	385	645	385	645
45°	29	421	29	421
60°	11	149	11	149
75°	0	5	0	5
90°	0	0	0	0

cd / 1000 lm

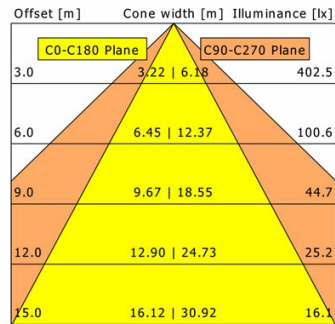

η	LED
Efficiency	112 lm/W
Direct/Indirect	↓ 100% / ↑ 0%
System Power	40 W
UGR	X=4H, Y=8H
Reflection factors	70/50/20
UGR C0/C180	20.5
UGR C90/C270	28.4
CIE Flux Codes	77 98 100 100 100
Ra/CRI	---

LTS

Zubehör



EU 10
Anbau-Stromschiene Professional
(Länge: 1000 mm)



EU 20
Anbau-Stromschiene Professional
(Länge: 2000 mm)



EU 21
Anbau-Stromschiene Professional
(Länge: 3000 mm)



EU 22
Anbau-Stromschiene Professional
(Länge: 4000 mm)



EUE 20
Einbau-Stromschiene Professional
(Länge: 2000 mm)



EUE 21
Einbau-Stromschiene Professional
(Länge: 3000 mm)



EUE 22
Einbau-Stromschiene Professional
(Länge: 4000 mm)



LAB 60
3-Phasen-Einbau-Monopoint mit Busoption



LAB 60 A
3-Phasen-Anbau-Monopoint mit Busoption



ST-A 10/9000-1-ST
Anbau-Stromschiene ONETrack mit Datenbus
(Länge: 1000 mm)



ST-A 20/9000-2-ST
Anbau-Stromschiene ONETrack mit Datenbus
(Länge: 2000 mm)



ST-A 30/9000-3-ST
Anbau-Stromschiene ONETrack mit Datenbus
(Länge: 3000 mm)

EL 303.2/B

Zubehör



ST-A 40/9000-4-ST
Anbau-Stromschiene ONETrack mit Datenbus
(Länge: 4000 mm)



ST-A MONO/9000-BPU-D
3-Phasen-Anbau-Monopoint mit Busoption



ST-E 10/9000-1-R
Einbau-Stromschiene ONETrack mit Datenbus
(Länge: 1000 mm)



ST-E 20/9000-2-R
Einbau-Stromschiene ONETrack mit Datenbus
(Länge: 2000 mm)



ST-E 30/9000-3-R
Einbau-Stromschiene ONETrack mit Datenbus
(Länge: 3000 mm)



ST-E 40/9000-4-R
Einbau-Stromschiene ONETrack mit Datenbus
(Länge: 4000 mm)



ST-E MONO/9000-BPU-D
3-Phasen-Einbau-Monopoint mit Busoption



ZBK 97
Blendklappe