

Typ-Nr.

E13002 E13003 E13004 E13005 E13006 E13007
 E13008 E13009 E13010 E13011 E13012 E13013
 E13014 E13015 E13016 E13017 E13018 E13019
 E13020 E13021 E13022 E13023 E13024 E13025
 E13183 E13184 E13185 E13186 E13187 E13188
 E13189 E13190 E13191 E13192 E13193 E13194

E14749 E14750 E14751 E14752 E14753 E14754
 E14755 E14756 E14757 E14758 E14759 E14760

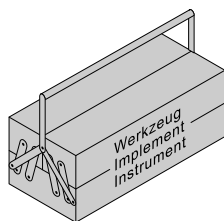
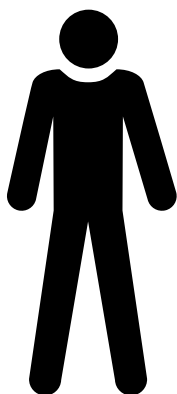
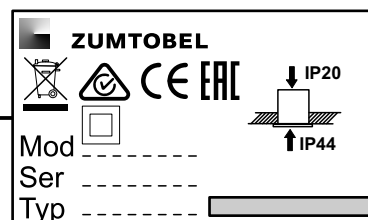
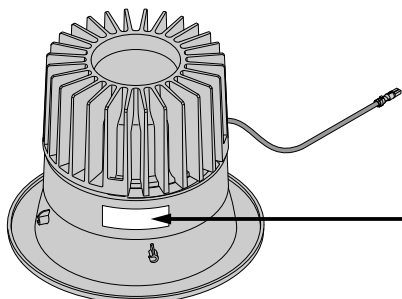
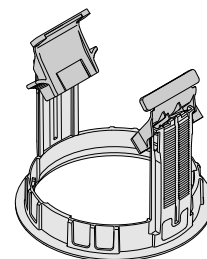
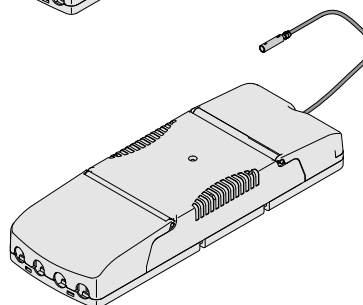
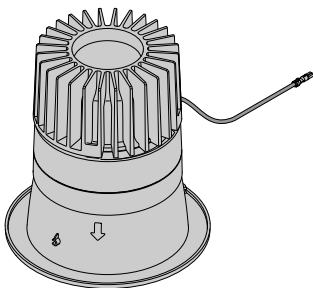
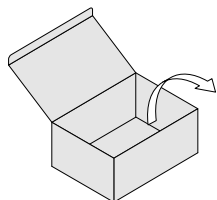
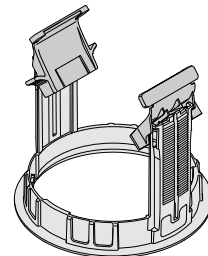
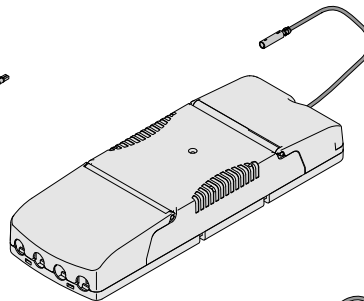
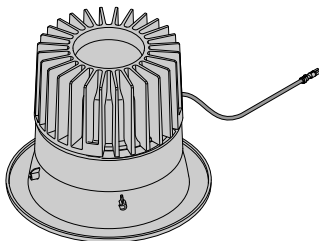
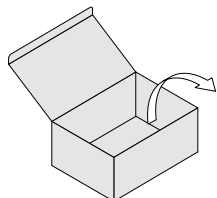
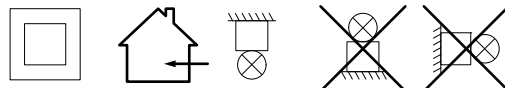

DE Die Montage und Inbetriebnahme darf nur von autorisiertem Fachpersonal durchgeführt werden.

GB Installation and commissioning may only be carried out by authorized specialists.

FR L'installation et la mise en service doivent obligatoirement être effectuées par des techniciens.

IT Montaggio ed avviamento devono essere eseguiti solo da personale specializzato.

NL De montage en inbedrijfstelling mogen enkel door erkend vakpersoneel worden uitgevoerd.

NO/SE Monteringen och idrifttagandet får endast företas av auktoriserad fackpersonal.

FI Asennuksen ja käyttöönoton saa tehdä vain auktorisoitu ammattihenkilöstö.

ES El montaje y la puesta en marcha sólo puede ser realizado por personal especializado autorizado.

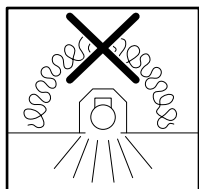
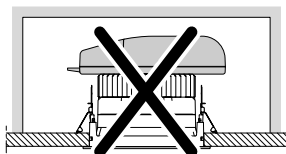

DE Leuchte darf nicht mit Wärmedämmung abgedeckt werden.

GB Luminaire not suitable for covering with thermally insulating material.

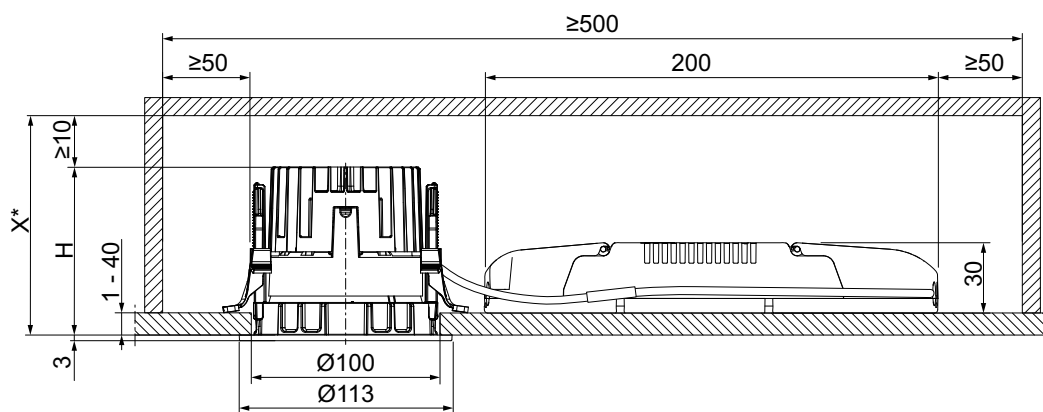

PANOS INF/ EVO...	H (mm)
R100 L	90
R100 H	120

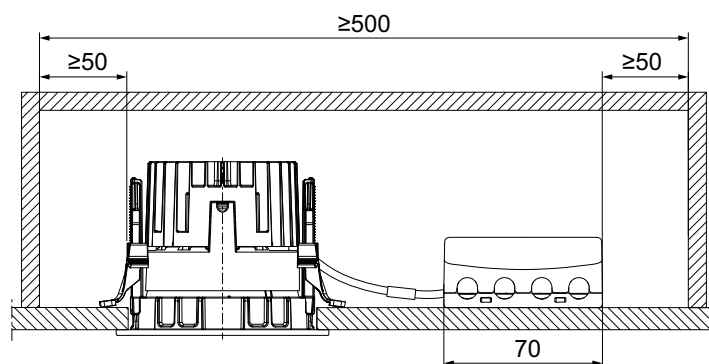

*

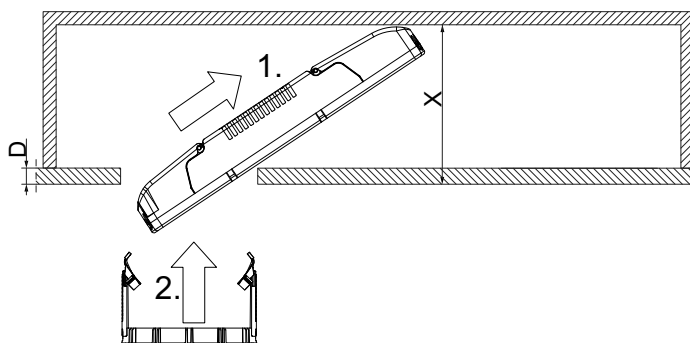

PANOS INF/EVO...	D (mm)	X (mm)	
		10W/11W	16W/18W
R100 L	1-15	100	110
	25	110	110
	40	130	130

PANOS INF/EVO...	D (mm)	X (mm)	
		10W/11W	16W/18W
R100 H	1-40	130	140

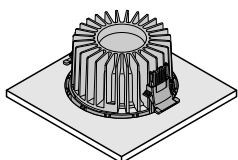

FR Le luminaire sert uniquement à l'éclairage et doit être installé conformément aux prescriptions nationales en matière d'installation. Toute autre utilisation ou installation est considérée comme "non conforme".

NO/SE Armaturen är uteslutande avsedd för belysning och ska installeras i enlighet med de nationella installationsbestämmelserna. All annan användning eller montering gäller som "icke ändamålsenlig".

DE Die Leuchte dient ausschließlich der Beleuchtung und ist entsprechend den nationalen Errichtungsbestimmungen zu installieren. Eine andere Nutzung oder ein anderer Einbau gilt als „nicht bestimmungsgemäß“.

IT L'apparecchio è destinato esclusivamente all'illuminazione e va installato in conformità alle leggi nazionali in vigore. Un altro impiego o un diverso tipo di montaggio non è considerato conforme alle disposizioni.

FI Valaisin on tarkoitettu ainoastaan valaistuskäyttöön, ja se on asennettava kansallisten määräysten mukaan. Muu käyttö tai muu asennus katsotaan sopimuksenvastaiseksi käytöksi.

GB The luminaire is used exclusively for lighting and is to be installed in accordance with the national installation regulations. Any other use or installation is regarded as "not according to instructions".

NL De lamp dient uitsluitend voor de verlichting en dient conform de nationale bouwbepalingen te worden geïnstalleerd. Een ander gebruik of een andere inbouw is niet conform.

ES La lámpara está destinada exclusivamente a la iluminación y debe ser instalada de acuerdo con las pertinentes normas nacionales. Cualquier otro uso o instalación no se considerará "previsto por la norma".

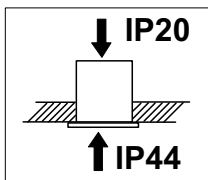

DE Voraussetzung für die Schutzart IP 44 der Leuchte ist die Installation in einer geschlossenen Decke! Die Schutzart IP 44 gilt nur von der Raumseite her.

GB The luminaire is protection type IP 44, only when being installed in an enclosed ceiling! Protection type IP 44 does not apply in the ceiling void itself.

FR L'installation dans un plafond fermé est nécessaire pour qu'une réalisation soit IP 44. La protection IP 44 ne joue que par rapport à la pièce.

IT La premessa per il tipo di protezione IP 44 dei modelli è l'installazione in uno spazio chiuso! Il sistema di protezione IP 44 riguarda solamente gli spazi laterali dai quali fuoreisce il fascio di luce.

NL Voorwaarde voor di classificatie IP 44 van het armatuur is, de installatie in een gesloten plafond. De classificatie IP 44 geldt alleen voor de ruimtezijde

NO/SE Armaturen har kapslingsgrad IP 44 bare når den er bygget inn i tett undertak. IP 44 gjelder bare nedenfra (fra rommet).

FI Kotelointiluokka IP 44 pätee vain umpikattoon asennetulle valaisimelle. Kotelointiluokka IP 44 pätee vain huoneen puolelta.

ES La luminaria equipada cumple con la protección IP 44 cuando se encuentra instalada en un techo cerrado. La protección IP 44 concierne únicamente la zona de la luminaria vista desde el interior del local.

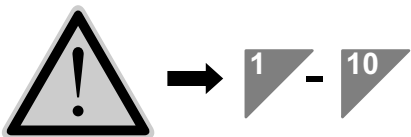

DE **Achtung!** Während der Verdrahtung und Installation der Leuchten und Versorgungsgeräte immer spannungslos arbeiten. Nichtbeachtung kann zur Zerstörung der LED- Module führen.

GB **Caution!** Make sure that the luminaires and power supply units are always disconnected from the mains supply during wiring and installation work. Otherwise, the LED modules may be destroyed.

FR **Attention!** Toujours travailler sans tension lors du câblage et de l'installation des luminaires et unités d'alimentation. Le non-respect de cette consigne peut entraîner la destruction des modules à LED.

IT **Attenzione!** Lavorare sempre in assenza di tensione mentre si cablano e si installano gli apparecchi e le unità di alimentazione. In caso contrario i moduli LED possono andare distrutti!

NL **Opgelet!** Tijdens het bedraden en installeren van de armaturen en voedingsapparaten altijd zonder spanning werken. Bij niet-naleving hiervan kunnen de LED-modules ernstig worden beschadigd.

NO/SE **OBS!** Koble alltid fra strømmen ved kabling og installasjon av lampene og strømforsyningsenhetene. LED-modulene kan ødelegges dersom dette ignoreres.

FI **Huom!** Valaisimien ja syöttölaitteiden kytkemisen ja asentamisen aikana on aina työskenneltävä jännitteettömästi. Muutoin led-moduulit voivat tuhoutua.

ES **Atención** Siempre mantenga desconectada la tensión al realizar las tareas de cableado y de instalación de las luminarias y dispositivos de alimentación. De lo contrario podría destruirse el módulo LED.



60800313

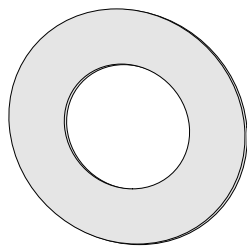

DE Bei dünnem oder weichem Deckenmaterial empfiehlt sich die Verwendung des Deckenverstärkungsringes zur Vergrößerung der Auflagefläche!

GB With thin or soft ceiling material it is recommended that ceiling reinforcing rings should be used to enlarge the bearing surface.

FR On recommande l'utilisation de la bague de renfort de plafond pour agrandir la surface portante lorsque le matériau du plafond est mince ou souple.

IT Con materiale coprente sottile o flessibile è consigliato l'impiego dell'anello di rinforzo della copertura per ingrandire la superficie d'appoggio!

NL Bij dun of zacht plafondmateriaal is het gebruik van de plafondverstevigende ring ter vergroting van het draagvlak aanbevelenswaardig!!

NO/SE For svakt eller mykt tildekkingsmateriale anbefaler vi bruk av forsterkingsringer for å øke anleggsflaten!

FI Kattomateriaalin ollessa ohutta tai pehmeää on katonvahvistusrenkaan käyttö suositeltavaa asetuspinnan suurentamiseksi.

ES En caso de material para cielorrasos fino o blando, se recomienda utilizar el aro de refuerzo de cielorrasos para agrandar la superficie de apoyo.

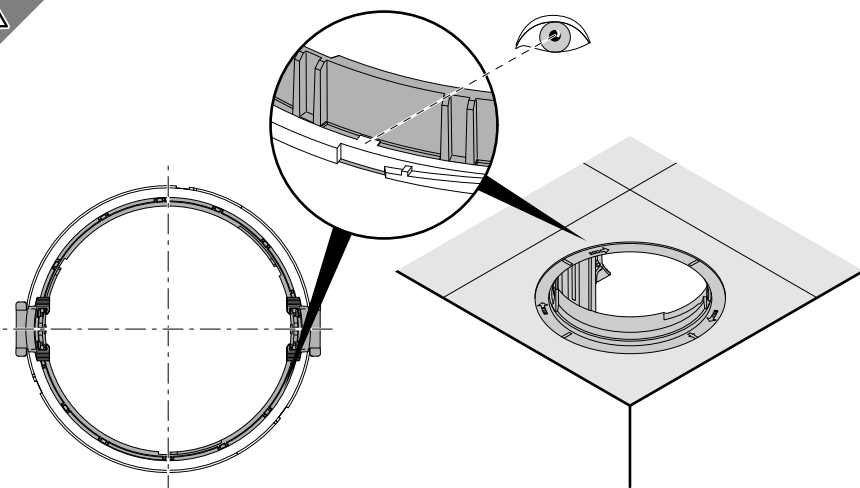

DE Montagering nur bei Zubehör

GB Mounting ring only for accessories

FR Bague de montage avec accessoires uniquement

IT Anello di montaggio solamente per l'accessorio

NL Montagering uitsluitend bij toebehoren

NO/SE Montagering bara vid tillbehör

FI Kiinnitysrenkas vain lisävarusteena

ES Anillo de montaje sólo en caso de accesorios

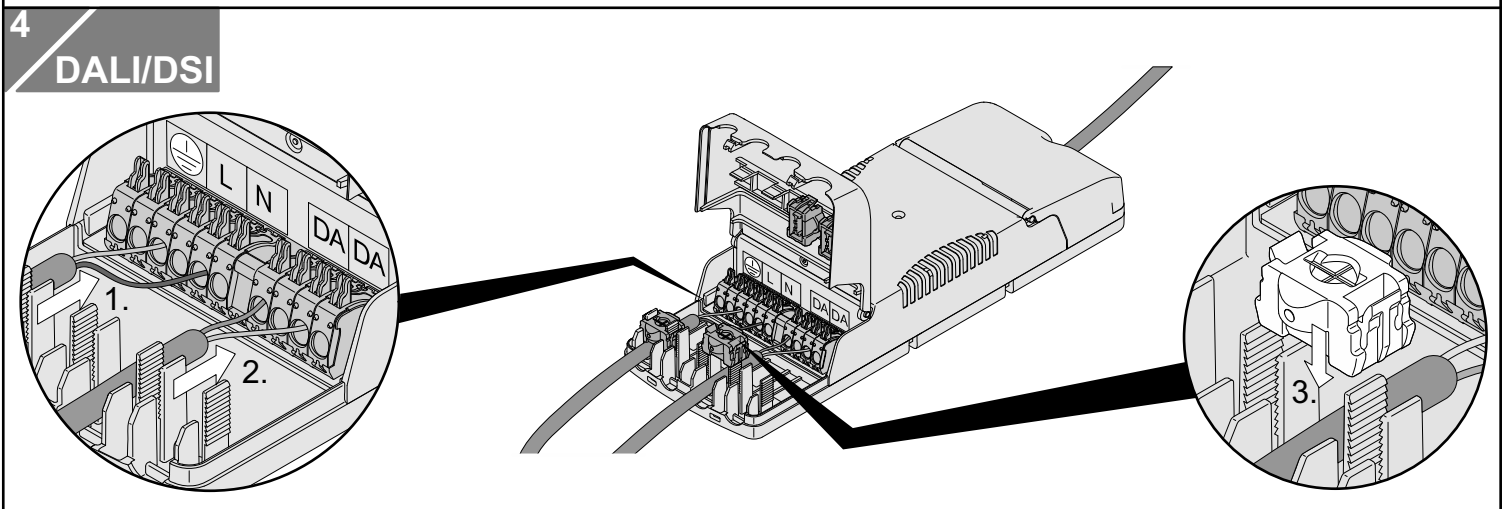
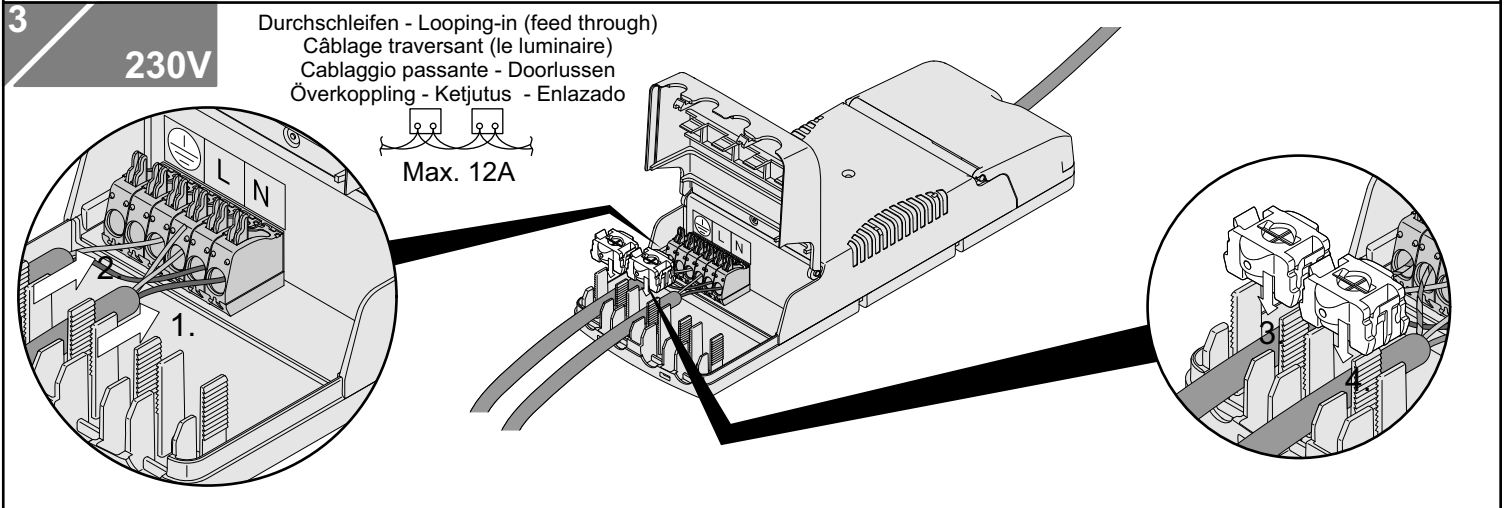
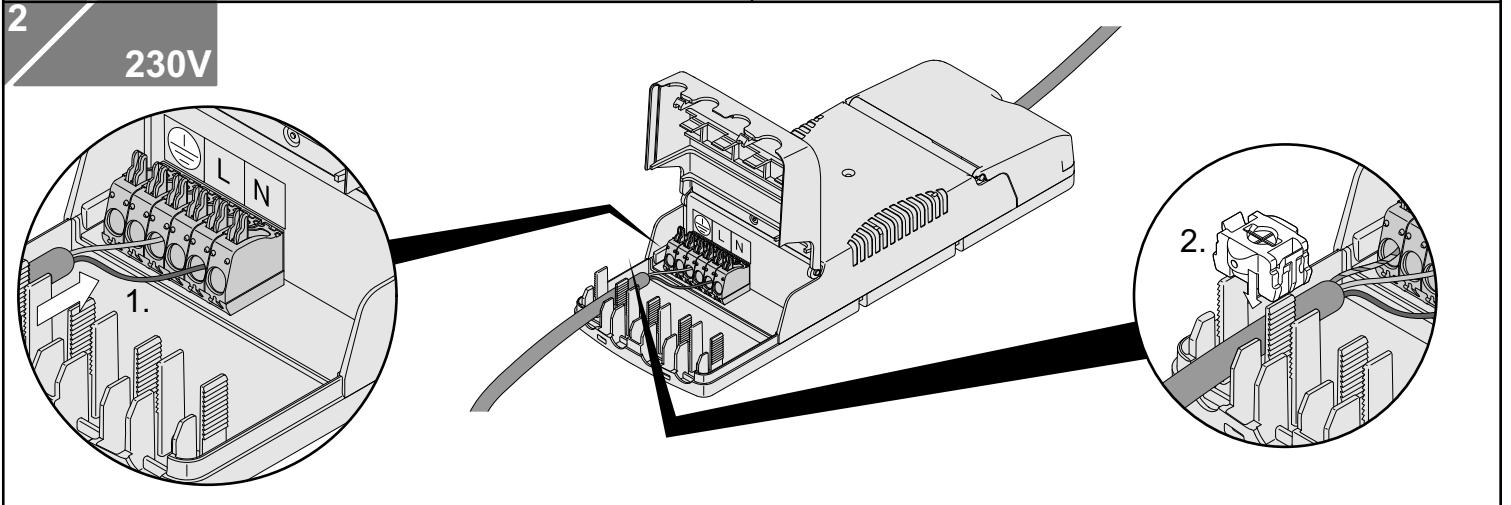
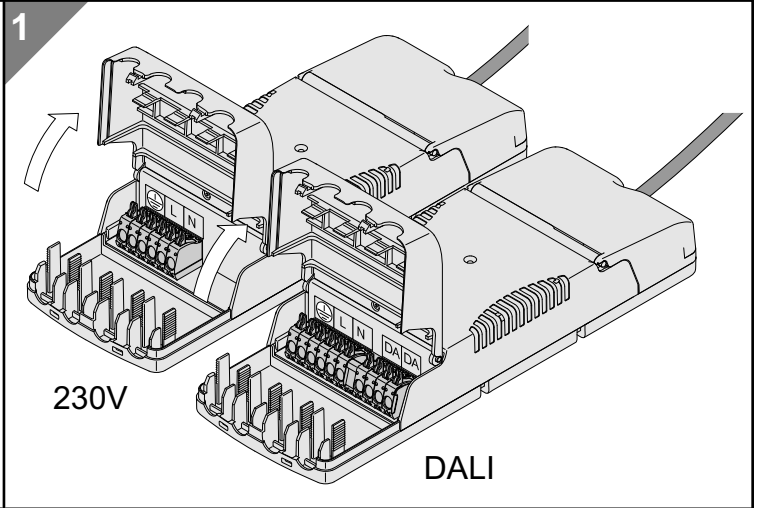
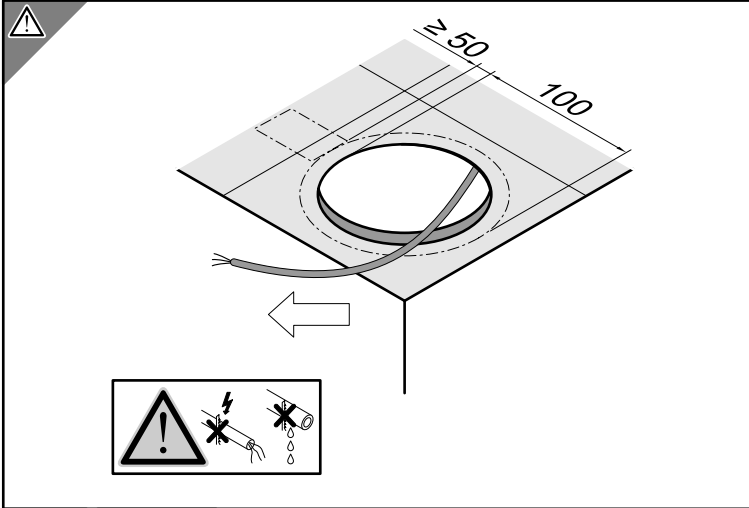

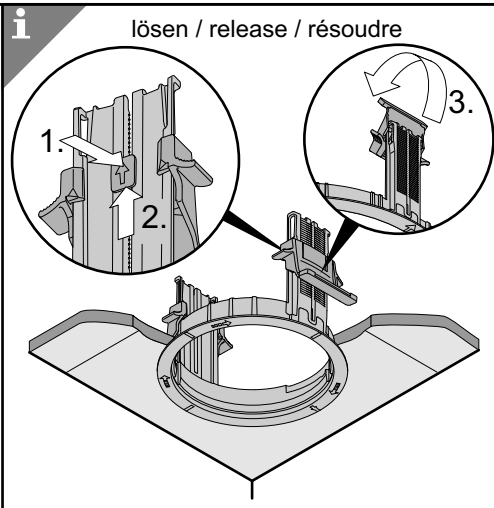
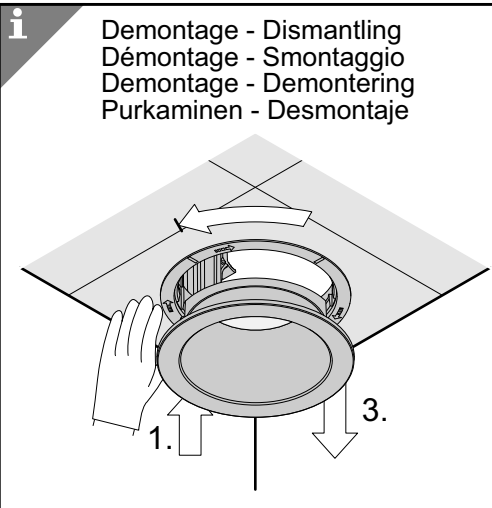
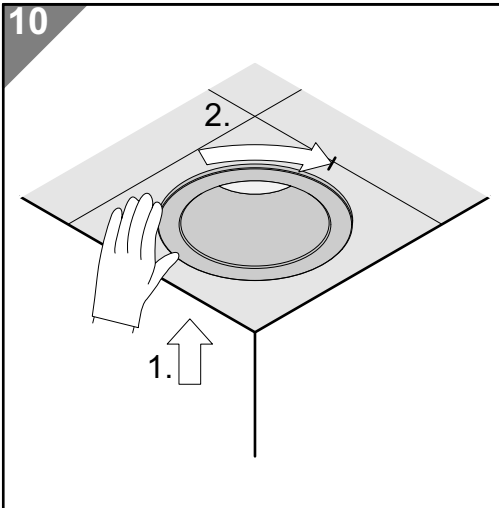

⚠

DE	Reflektorreinigung
GB	Reflector cleaning
FR	Nettoyage du réflecteur
IT	Pulizia di riflettori
NL	Reflektorreiniging
NO/SE	Reflektorrengöring
FI	Reflektorin puhdistus
ES	Limpieza del reflector

i

60 800 118

DE	Reflektorreinigungstuch
GB	Reflector cleaning cloth
FR	Chiffon de nettoyage du réflecteur
IT	Straccio per la pulizia di riflettori
NL	Reinigingsdoek voor reflector
NO/SE	Reflektorrengöringsduk
FI	Reflektorinpuhdistusliina
ES	Paño para limpiar el reflector

⚠

mode of operation: 0/1
 facilities: A...F

DE	Leuchten für Notlicht nach EN 60598-2-22. Diese Leuchte ist nur für Anlagen bestimmt, in denen die Steckverbindung vor unbefugtem Trennen geschützt ist.
GB	Option Emergency Lighting EN 60598-2-22. This luminaire is exclusively intended for systems with a plug-in connection that is protected against unauthorized disconnecting.
FR	Option Emergency Lighting EN 60598-2-22. Ce luminaire est uniquement destiné aux installations où le connecteur est protégé contre toute déconnexion involontaire.
IT	Opzione luce di emergenza EN 60598-2-22. Questo apparecchio è destinato unicamente ad impianti in cui non è possibile staccare l'innesto se non dietro autorizzazione.
NL	Optie Emergency Lighting EN 60598-2-22. Deze armatuur is enkel bedoeld voor installaties waarbij de steekverbinding beschermd is tegen onbedoelde ont koppeling.
NO/SE	Option Emergency Lighting EN 60598-2-22. Denna armatur är endast avsedd för anläggningar i vilka stickkontakten inte kan dras ut av obehöriga.
FI	Lisävaruste hätävalaisin EN 60598-2-22. Tämä valaisin on tarkoitettu vain sellaisille laitteistoille, joissa pistoliitäntä on suojattu tahattomalta katkaisulta.
ES	Opción Emergency Lighting EN 60598-2-22. Esta luminaria está destinada únicamente a sistemas en los que el conector enchufable está protegido contra su separación imprevista.

Technische Änderungen vorbehalten. - Specifications subject to change without notice. - Modifications techniques sans préavis.
 Modificazione tecnica senza preavviso. - Technische wijzigingen voorbehouden.
 Med forbehold om tekniske endringer. - Oikeudet teknisiin muutoksiin pidätetään. - Modificaciones técnicas sin preaviso.