

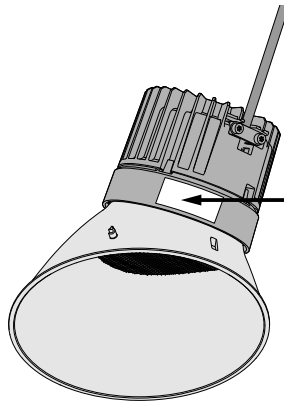

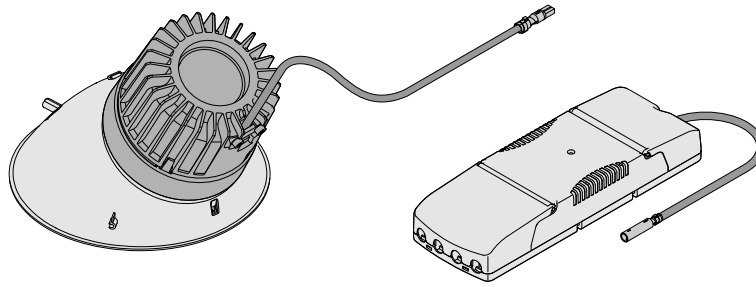

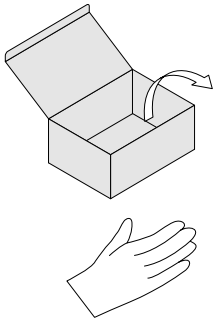

Typ-Nr. E13262 E13263
E14773 E14774

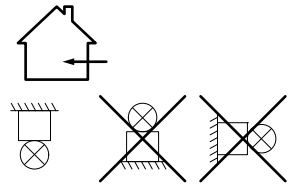

	ZUMTOBEL			
	CE		EAC	
Mod	-----			
Ser	-----			
Typ	-----			... W LED ...mA

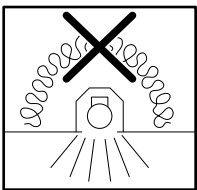
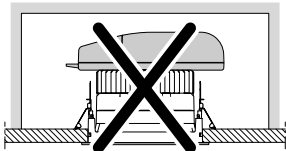

DE Leuchte darf nicht mit Wärmedämmung abgedeckt werden.

GB Luminaire not suitable for covering with thermally insulating material.

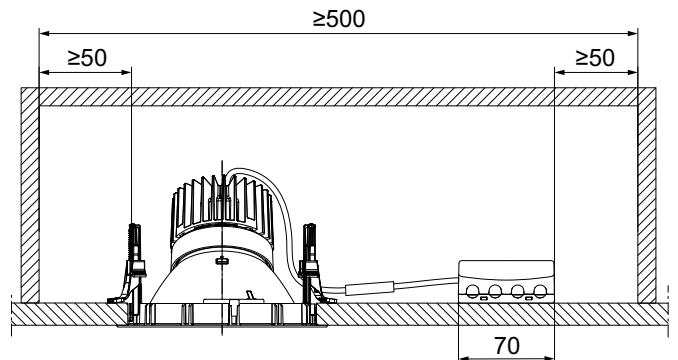
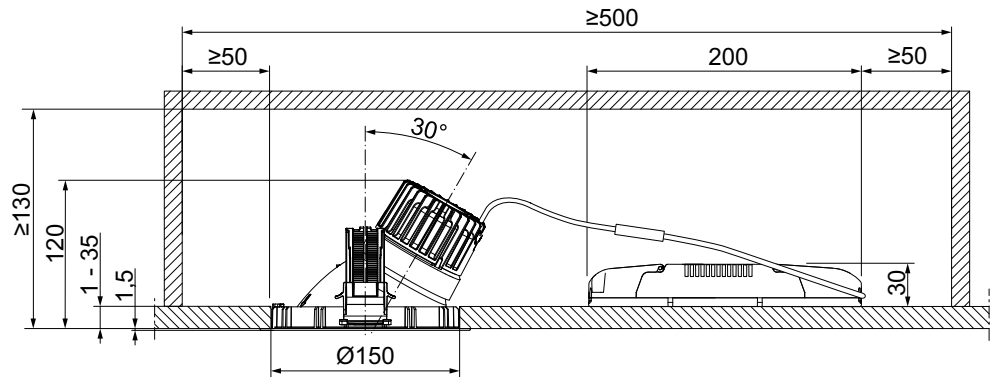

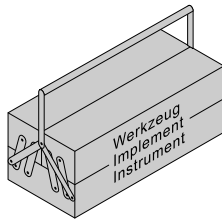
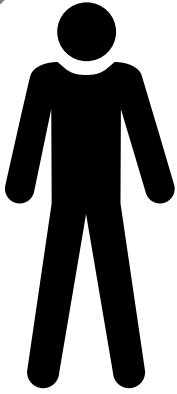

DE Die Montage und Inbetriebnahme darf nur von autorisiertem Fachpersonal durchgeführt werden.

NL De montage en inbedrijfstelling mogen enkel door erkend vakpersoneel worden uitgevoerd.

GB Installation and commissioning may only be carried out by authorized specialists.

NO/SE Monteringen och idrifttagandet får endast företas av auktoriserad fackpersonal.

FR L'installation et la mise en service doivent obligatoirement être effectuées par des techniciens.

FI Asennuksen ja käyttöönoton saa tehdä vain auktorisoitu ammattihenkilöstö.

IT Montaggio ed avviamento devono essere eseguiti solo da personale specializzato.

ES El montaje y la puesta en marcha sólo puede ser realizado por personal especializado autorizado.

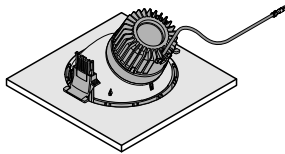

DE Die Leuchte dient ausschließlich der Beleuchtung und ist entsprechend den nationalen Errichtungsbestimmungen zu installieren. Eine andere Nutzung oder ein anderer Einbau gilt als „nicht bestimmungsgemäß“.

FR Le luminaire sert uniquement à l'éclairage et doit être installé conformément aux prescriptions nationales en matière d'installation. Toute autre utilisation ou installation est considérée comme "non conforme".

NO/SE Armaturen är uteslutande avsedd för belysning och ska installeras i enlighet med de nationella installationsbestämmelserna. All annan installation eller montering gäller som "icke ändamålsenlig".

GB The luminaire is used exclusively for lighting and is to be installed in accordance with the national installation regulations. Any other use or installation is regarded as "not according to instructions".

IT L'apparecchio è destinato esclusivamente all'illuminazione e va installato in conformità alle leggi nazionali in vigore. Un altro impiego o un diverso tipo di montaggio non è considerato conforme alle disposizioni.

FI Valaisin on tarkoitettu ainoastaan valaistuskäyttöön, ja se on asennettava kansallisten määräysten mukaan. Muu käyttö tai muu asennus katsotaan sopimuksenvastaiseksi käytöksi.

NL De lamp dient uitsluitend voor de verlichting en dient conform de nationale bouwbepalingen te worden geïnstalleerd. Een ander gebruik of een andere inbouw is niet conform.

ES La lámpara está destinada exclusivamente a la iluminación y debe ser instalada de acuerdo con las pertinentes normas nacionales. Cualquier otro uso o instalación no se considerará "previsto por la norma".

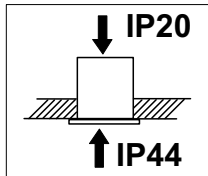

DE Voraussetzung für die Schutzart IP 44 der Leuchte ist die Installation in einer geschlossenen Decke! Die Schutzart IP 44 gilt nur von der Raumseite her.

FR L'installation dans un plafond fermé est nécessaire pour qu'une réalisation soit IP 44. La protection IP 44 ne joue que par rapport à la pièce.

NO/SE Armaturen har kapslingsgrad IP 44 bare når den er bygget inn i tett undertak. IP 44 gjelder bare nedenfra (fra rommet).

GB The luminaire is protection type IP 44, only when being installed in an enclosed ceiling! Protection type IP 44 does not apply in the ceiling void itself.

IT La premessa per il tipo di protezione IP 44 dei modelli è l'installazione in uno spazio chiuso! Il sistema di protezione IP 44 riguarda solamente gli spazi laterali dai quali fuoriesce il fascio di luce.

FI Kotelointiluokka IP 44 pätee vain umpikattoon asennetulle valaisimelle. Kotelointiluokka IP 44 pätee vain huoneen puolelta.

NL Voorwaarde voor de classificatie IP 44 van het armatuur is, de installatie in een gesloten plafond. De classificatie IP 44 geldt alleen voor de ruimtezijde

ES La luminaria equipada cumple con la protección IP 44 cuando se encuentra instalada en un techo cerrado. La protección IP 44 concierne únicamente la zona de la luminaria vista desde el interior del local.

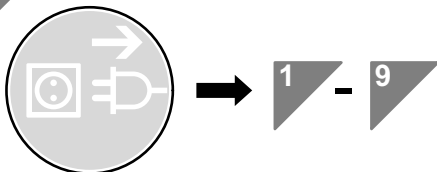

FR **Attention!** Toujours travailler sans tension lors du câblage et de l'installation des luminaires et unités d'alimentation. Le non-respect de cette consigne peut entraîner la destruction des modules à LED.

NO/SE **OBS!** Koble alltid fra strømmen ved kabling og installasjon av lampene og strømforsyningsenhetene. LED-modulene kan ødelegges dersom dette ignoreres.

DE **Achtung!** Während der Verdrahtung und Installation der Leuchten und Versorgungsgeräte immer spannungslos arbeiten. Nichtbeachtung kann zur Zerstörung der LED-Module führen.

IT **Attenzione!** Lavorare sempre in assenza di tensione mentre si cablano e si installano gli apparecchi e le unità di alimentazione. In caso contrario i moduli LED possono andare distrutti!

FI **Huom!** Valaisimien ja syöttölaitteiden kytkemisen ja asentamisen aikana on aina työskenneltävä jännitteettömästi. Muutoin led-moduulit voivat tuhoutua.

GB **Caution!** Make sure that the luminaires and power supply units are always disconnected from the mains supply during wiring and installation work. Otherwise, the LED modules may be destroyed.

NL **Opgelet!** Tijdens het bedraden en installeren van de armaturen en voedingsapparaten altijd zonder spanning werken. Bij niet-naleving hiervan kunnen de LED-modules ernstig worden beschadigd.

ES **Atención** Siempre mantenga desconectada la tensión al realizar las tareas de cableado y de instalación de las luminarias y dispositivos de alimentación. De lo contrario podría destruirse el módulo LED.

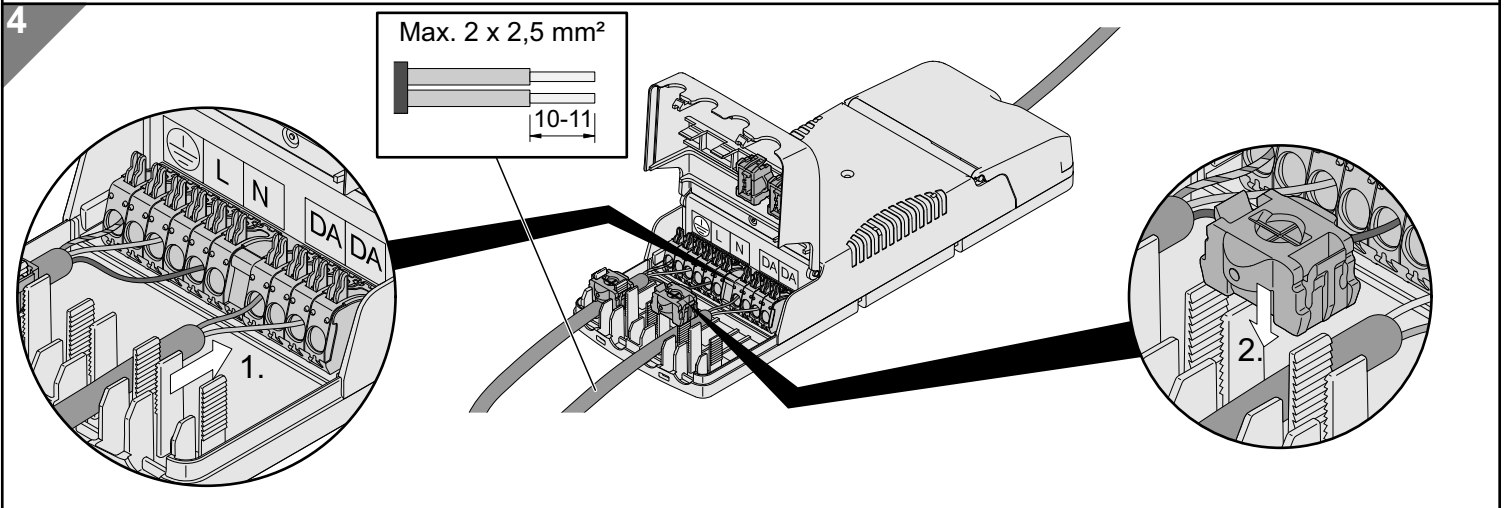
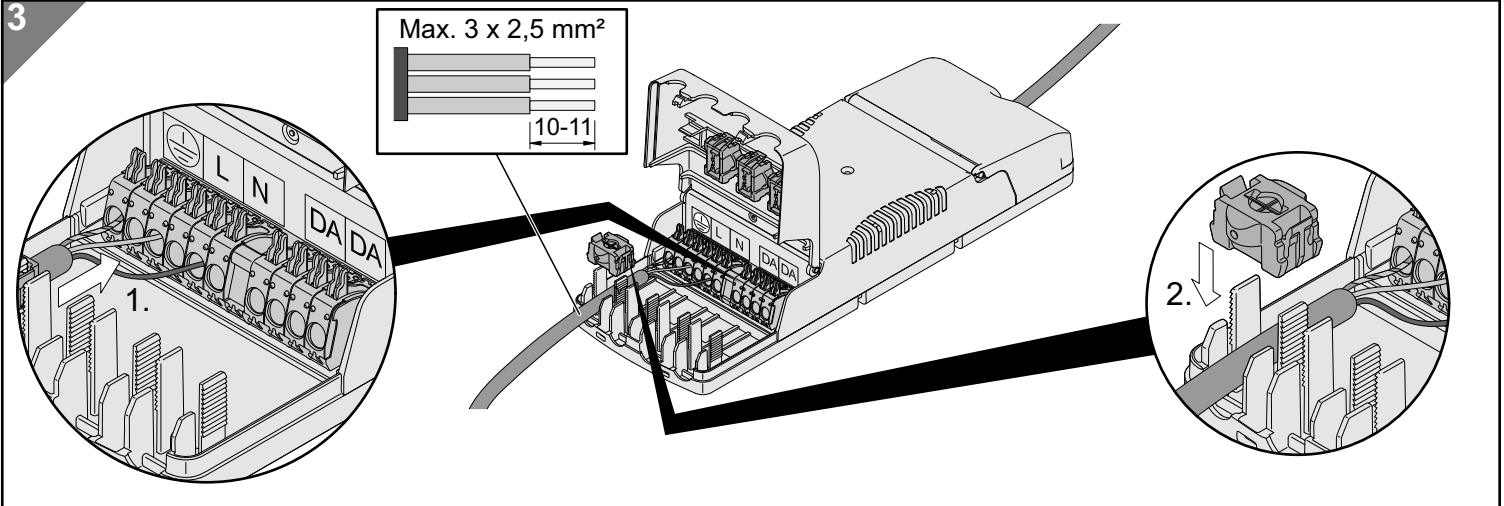
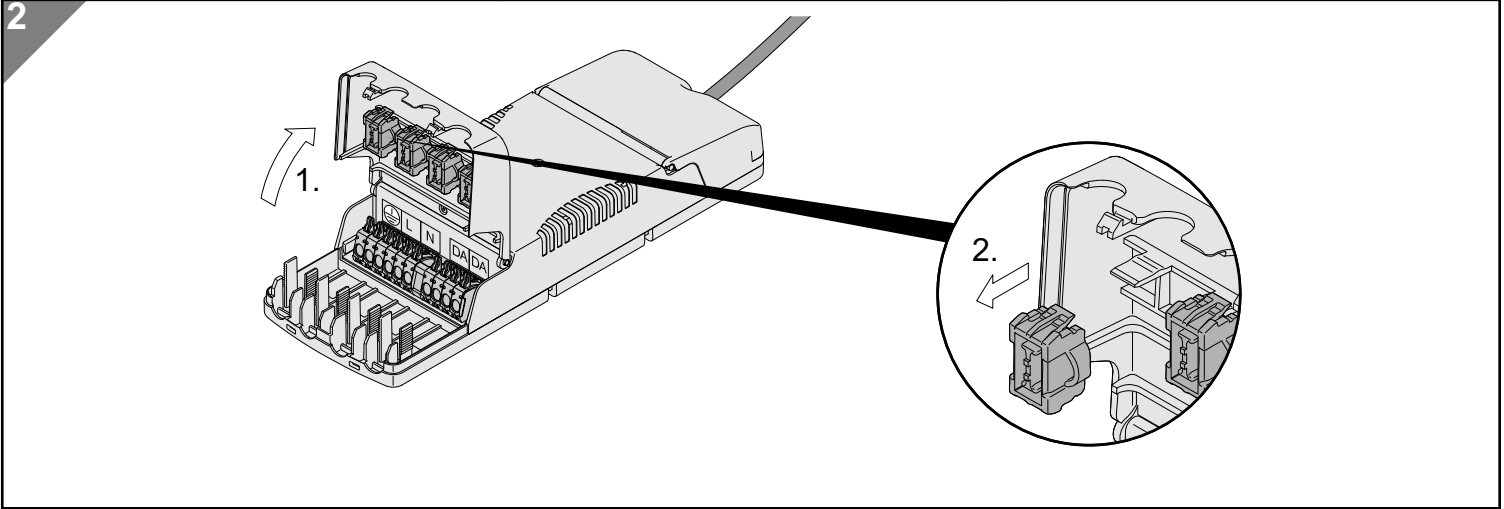
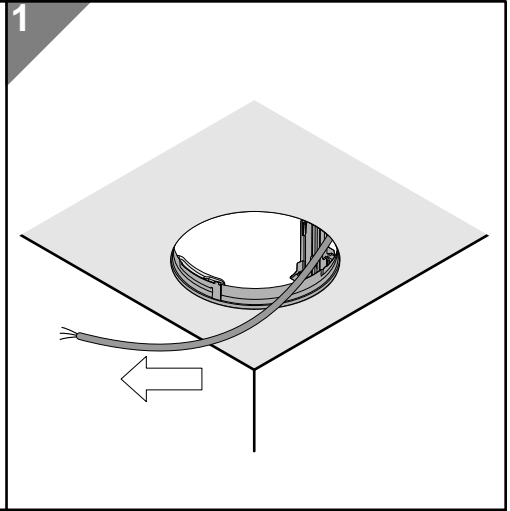
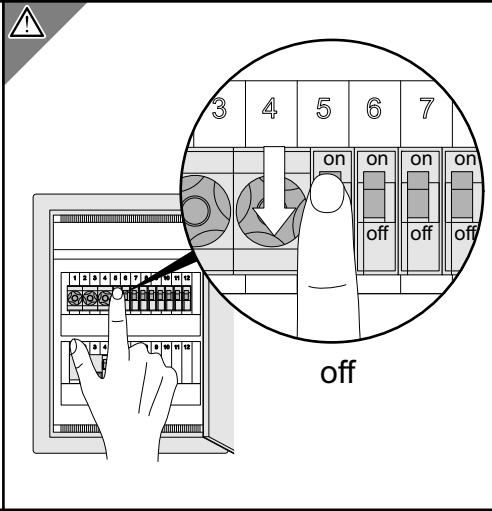
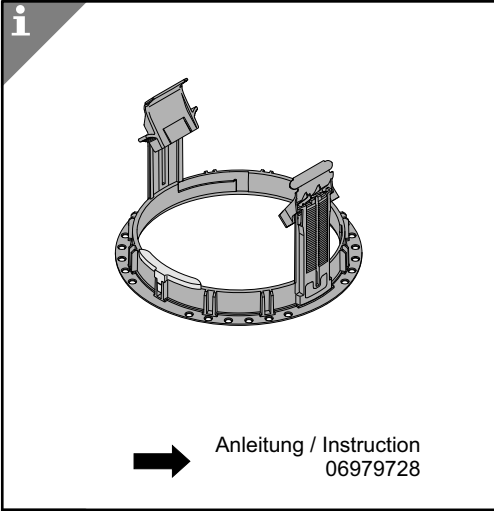

5

Durchschleifen - Looping-in (feed through)
Câblage traversant (le luminaire)
Cablaggio passante - Doorlussen
Överkoppling - Ketjutus - Enlazado

max. 12A

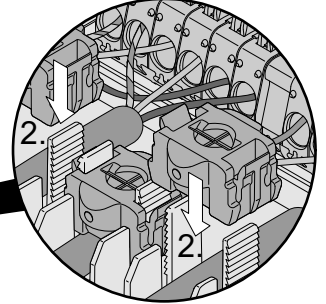
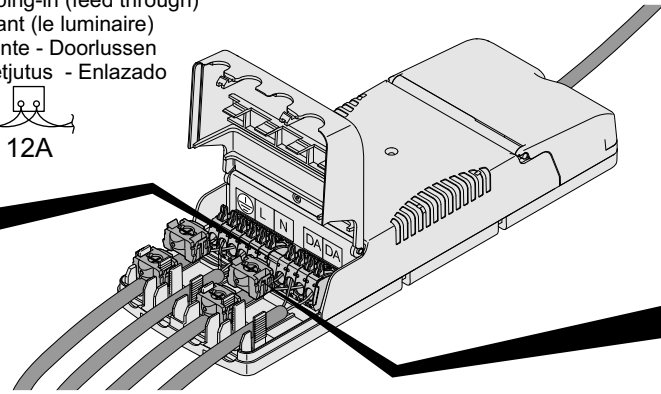
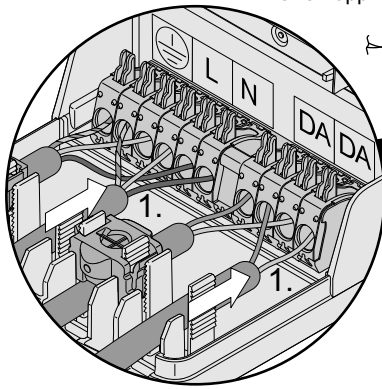

i

switchDIM

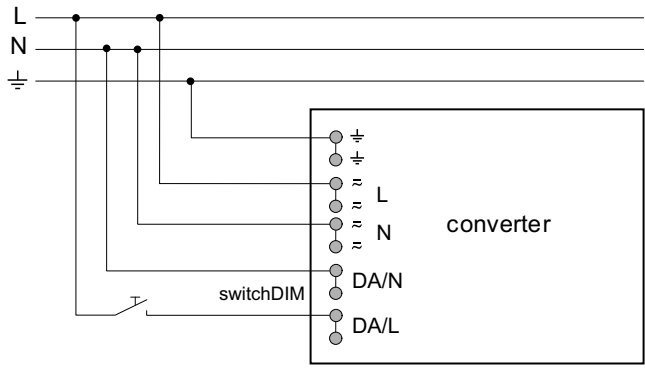

6

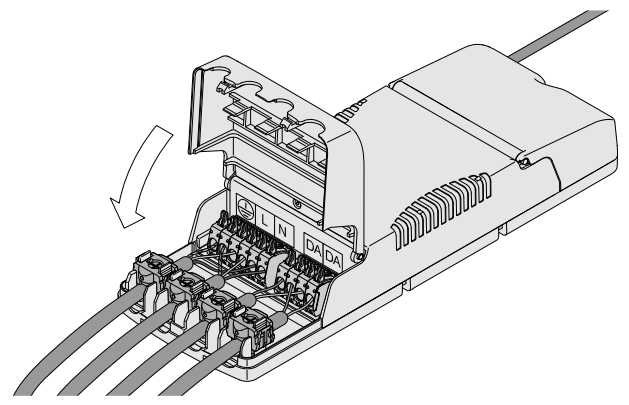

7

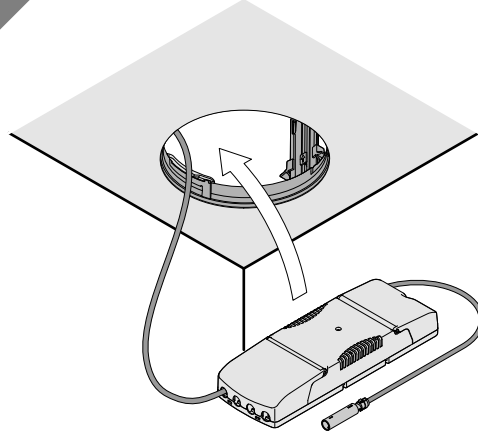

8

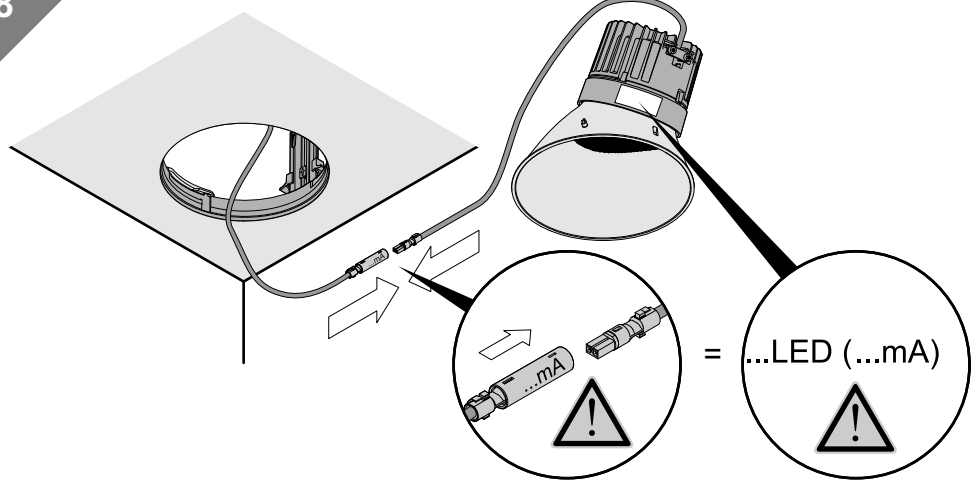

i

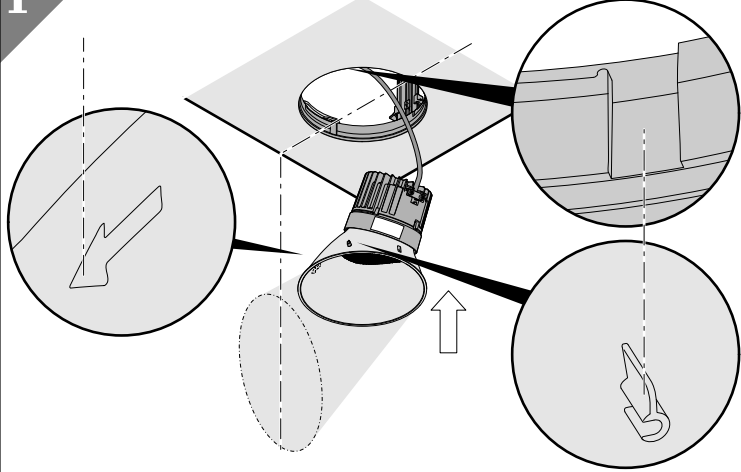

9

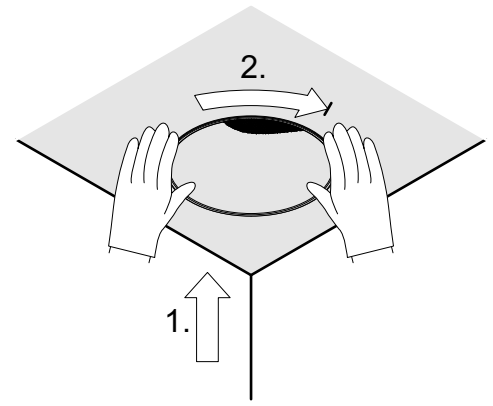



Demontage - Dismantling - Démontage - Smontaggio
 Demontage - Demontering - Purkaminen - Desmontaje

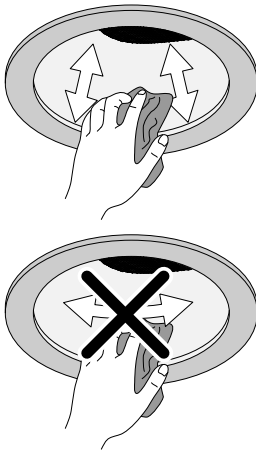
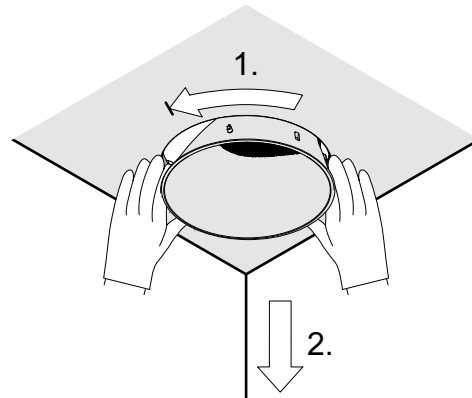

DE Reflektorreinigung

NL Reflectorreiniging

GB Reflector cleaning

NO/SE Reflektorrengöring

FR Nettoyage du réflecteur

FI Reflektorin puhdistus

IT Pulizia di riflettori

ES Limpieza del reflector



60 800 118



DE Reflektorreinigungstuch

NL Reinigingsdoek voor reflector

GB Reflector cleaning cloth

NO/SE Reflektorrengöringsduk

FR Straccio per la pulizia di riflettori

FI Reflektorinpuhdistusliina

IT Pulizia di riflettori

ES Paño para limpiar el reflector

Technische Änderungen vorbehalten. - Specifications subject to change without notice. - Modifications techniques sans préavis.
 Modifiche tecniche senza preavviso. - Technische wijzigingen voorbehouden.
 Med forbehold om tekniske endringer. - Oikeudet teknisiin muutoksiin pidätetään. - Modificaciones técnicas sin preaviso.