

**FRANCAIS**

-Remplacer toute protection fissurée.  
-Les luminaires classe II doivent être installés de façon à ce que la partie métallique ne soit pas en contact avec l'installation électrique connectée à la terre.

**ATTENTION:** Les luminaires classe I doivent être reliés à la terre.  
-Ce luminaire fonctionne à une tension nominale qui doit être coupée avant toute intervention sur l'appareillage.  
-Toute modification de cet appareil est interdite.  
-Respecter la distance minimale par rapport aux objets éclairés définie par ce sigle.

**SVERIGE**

-Ersätta alla spräckta skyddsplåtar.  
-Klass II armaturer måste installeras så att nakna metalldelar i armaturen inte är i kontakt med någon elektrisk installation, kopplad till en skyddledare.

**WARNING:** Klass I armaturer måste vara jordade.  
-Denna armatur fungerar med högspänning som måste vara fränslagen före ingripande i driftdonen.  
-Alla ändringar i denna armatur är förbjuden.

**ITALIANO**

-Sostituire sempre tutte le protezioni danneggiate.  
-Gli apparecchi in classe II devono essere installati in modo che le parti metalliche non siano in contatto con apparati elettrici collegati a terra.

**ATTENZIONE:** Gli apparecchi in class I devono essere collegati a terra.  
-Questo apparecchio funziona a tensione nominale, questa deve essere interrotta prima di ogni intervento sul gruppo di alimentazione.  
-Ogni modifica dell' apparecchio è proibita.

**ENGLISH**

-Replace any cracked protective shield.  
-Class II luminaires must be installed so that exposed metal work of the luminaire is not in contact with any part of the electrical installation connected to a protective conductor.

**WARNING:** Class I luminaires must be earthed.  
-This luminaire operates at mains voltage which must be switched off before intervention in control gear.  
-Any modification to this luminaire is forbidden.  
-Lighted objects nearer than the minimal distance in the is forbidden.

**DEUTSCH**

-Ersetze jede gebrochene Schutzscheibe.  
-Schutzklasse II Leuchten müssen so installiert werden, daß berührbare Metallteile nicht mit einem, an dem Schutzleiter angeschlossenen Teil der elektrischen Installation in Kontakt kommen können.

**ACHTUNG:** Schutzklasse I Leuchten müssen geerdet sein.  
-Diese Leuchte wird mit Netzspannung betrieben. Bevor Eingriffe am Vorschaltgerät vorgenommen werden sowie vor Wartung und Installation, ist die Versorgungsspannung abzuschalten.  
-Jede Änderung an dieser Leuchte ist verboten.

**SUOMI**

-Rikkoontunut suojalasi vaihdettava välittömästi uuteen vastaavaan.  
-Asennettaessa suojausluokan II valaisinta on peruseristetyin johdon ja kosketteltavien metalliosien välinen kosketus tehokkaasti eristettävä.

**VAROITUS:** Suojausluokan I valaisin täytyy maadoittaa.  
-Verkköjännite on kytkettävä pois ennen valaisimen huoltotoimenpiteitä.  
-Valaisimen rakennetta ei saa muuttaa.

- |                                     |                                   |                                    |
|-------------------------------------|-----------------------------------|------------------------------------|
| <b>UK</b> Installation instructions | <b>FI</b> Asennusohje             | <b>LV</b> Instalācijas instrukcija |
| <b>DE</b> Montageanleitung          | <b>FR</b> Notice de montage       | <b>NO</b> Monteringsanvisning      |
| <b>CZ</b> Montážní návod            | <b>HU</b> Szerelési útmutató      | <b>PL</b> Instrukcja montażu       |
| <b>DK</b> Monteringsvejledning      | <b>IT</b> Istruzioni di montaggio | <b>SE</b> Installationsanvisning   |
| <b>EE</b> Paigaldusjuhend           | <b>LT</b> Montavimo Instrukcijos  | <b>RU</b> ИНСТРУКЦИЯ ПО МОНТАЖУ    |

TYPE : URBA - ECO

The luminaire with clear optic should be positioned so that prolonged staring into the luminaire at a distance <1.5m is not expected

4 T20 PZ1 46 24 19 13

LED CLASS I CLASS II CE IP66 IK09 MSU / MSU-IN IK10 MTP / MCA

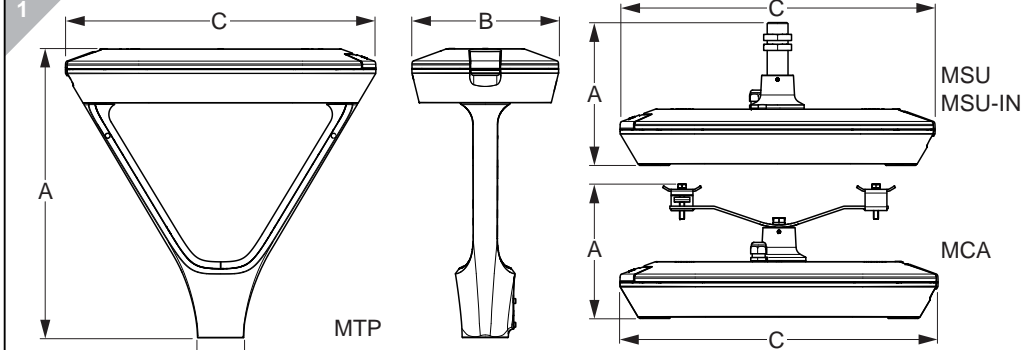

ECO						
	A	B	C	D	(kg)	SCx (m <sup>2</sup> )
MTP Ø60	474	241	510	76	7,5	0,049
MTP Ø76	494	241	510	97	7,85	0,051
MSU / MSU-IN	231	241	510		6,7	0,031
MCA	215	241	510		7	0,031

