

FILLER

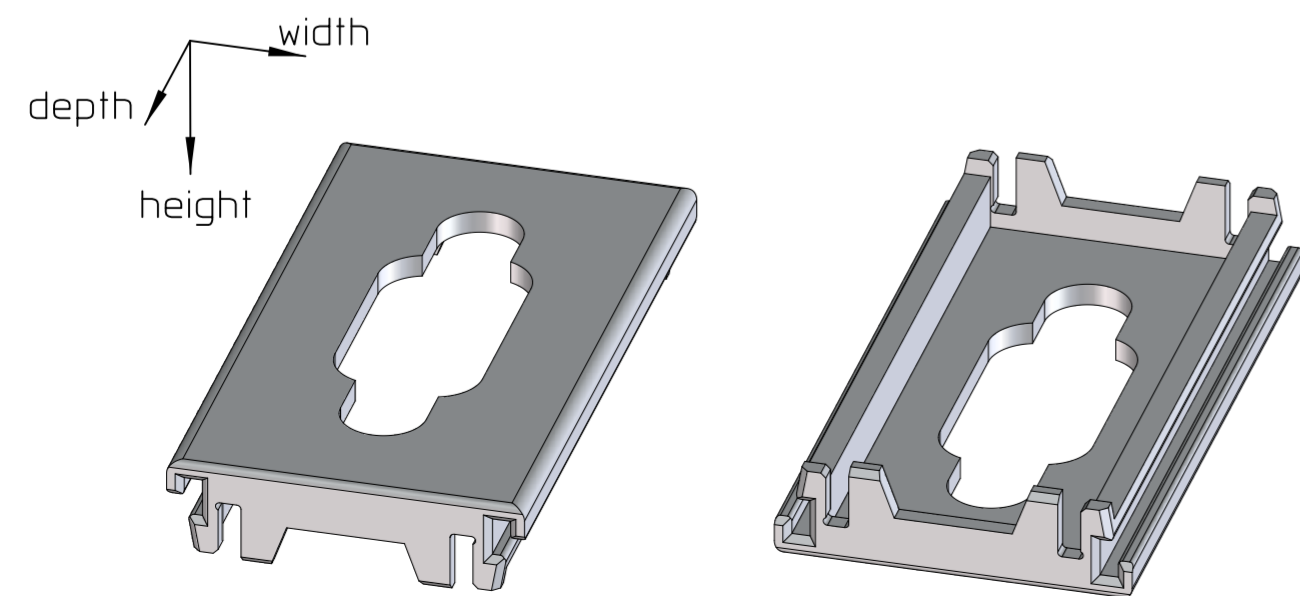

Assembly example

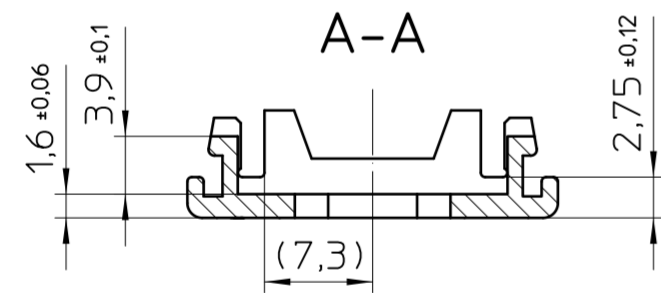
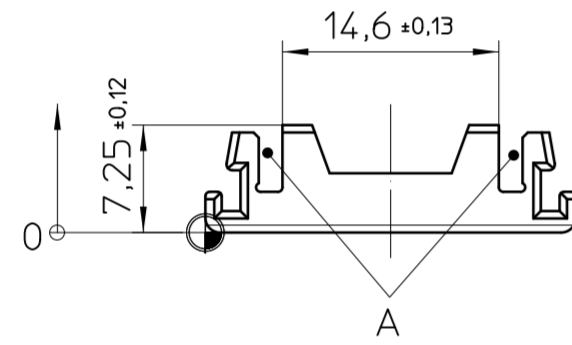
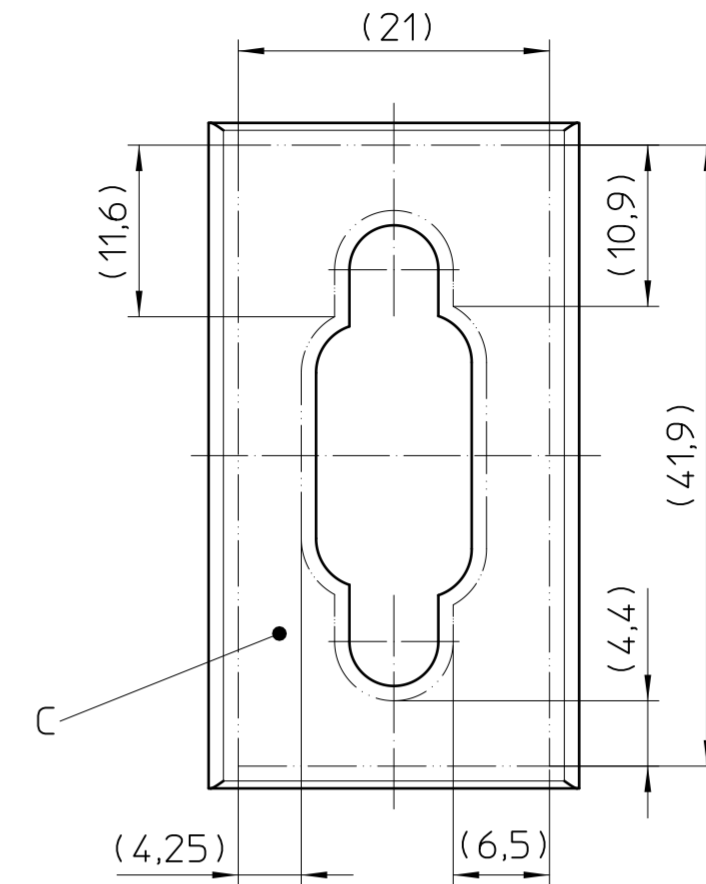
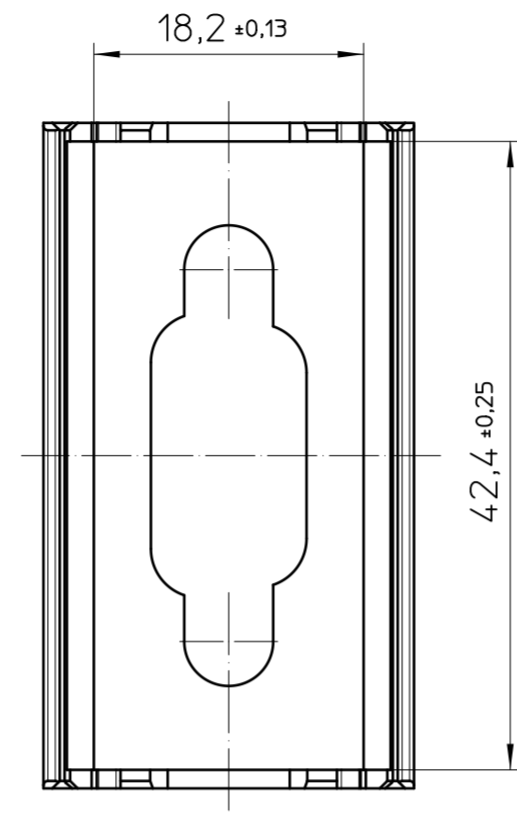
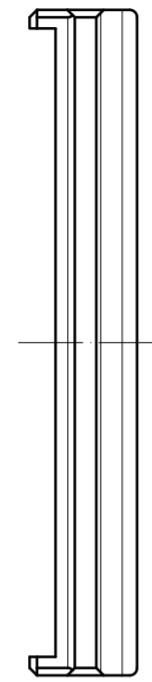
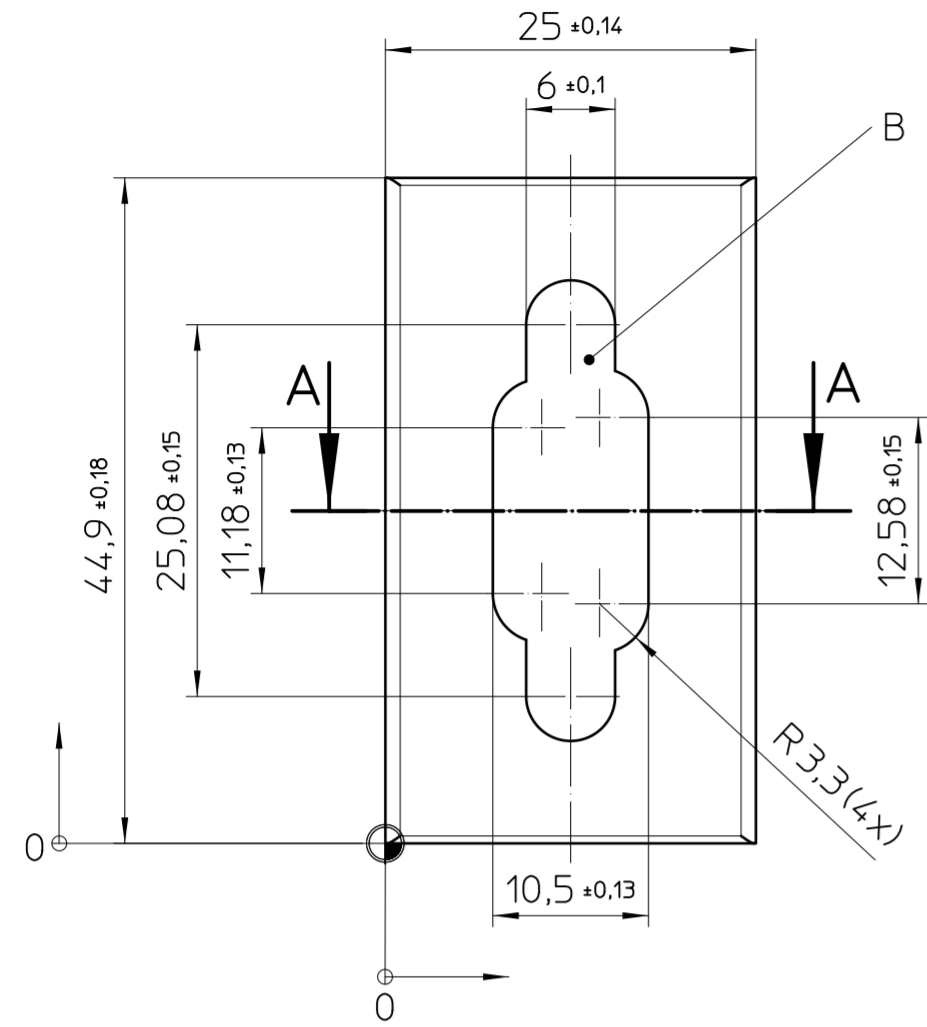
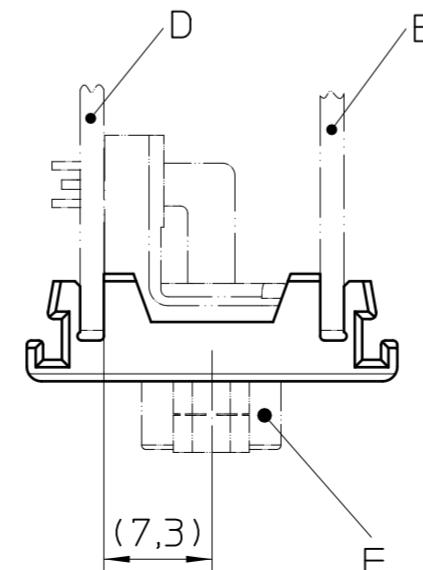
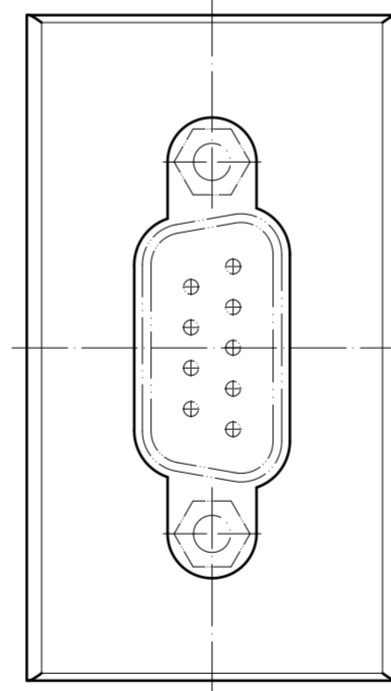

General Information:

- Simplified representation, exemplary shown in gray
- Document excluded from change process
- Units are in millimeters [mm] and degrees [°]
- Tolerances apply in a normal climate according to DIN EN ISO 291-23/50-2, PA plastic parts with about 2% (% by weight) moisture content.
- Workpiece zero point for printing processing
- Tolerances for printing DIN ISO 2768-m
- Web: www.phoenixcontact.com webcode: #1635

Additional Information:

- A. PCB guidance
- B. Opening for connectors D-SUB 9
- C. Marking area for pad printing, other printing process on request
- D. Main PCB, thickness= 1,6±0,2
- E. Second PCB, thickness= 1,6±0,2
- F. Connector D-SUB 9

Pos.	QTY	Description	Material
1	1	FILLER	PA
DIN A2		document-No. / RI 01119618 / 02	date 08.04.2025
1053054		document-type TECDOC 2D_Productdrawing	scale 2:1
page 1 of 1		description ICS25-F45D9-7035	

Transfer or duplication of this document as well as the utilisation or communication of its content are not permitted unless express consent is granted. Violations give rise to claims for damages. All rights reserved in case of patent, utility model or design patent registrations.

Weitergabe sowie Vervielfältigung dieses Dokuments, Verwertung und Mitteilung seines Inhalts sind verboten, soweit nicht ausdrücklich gestattet. Zuwiderhandlungen verpflichten zu Schadensersatz. Alle Rechte für den Fall der Patent-, Gebrauchsmuster- oder Designeintragung vorbehalten.