

Connector Location A

Connector Location B

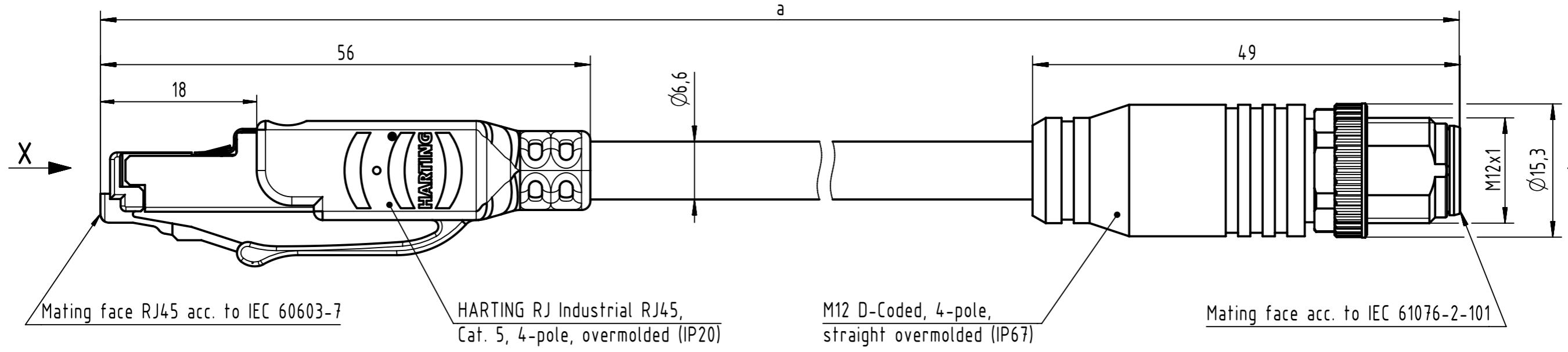

X male

Y male

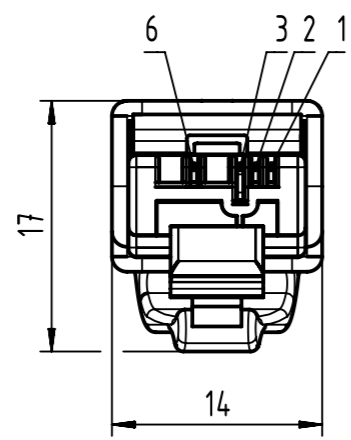

Loading Plan

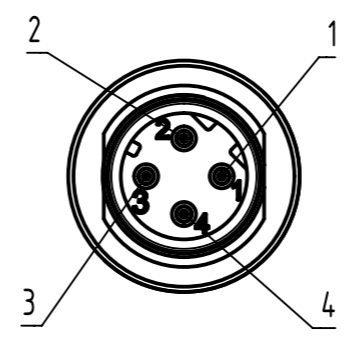
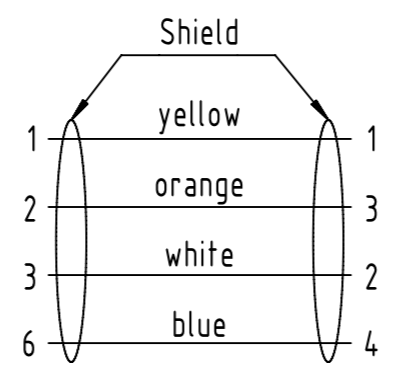

length in "1m" step	100	XXX=000
	99	XXX=990
	12	XXX=120
	11	XXX=110
length in "0.1m" step	10	XXX=100
	9.9	XXX=099
	9.8	XXX=098
	0.5	XXX=005
	0.4	XXX=004
	0.3	XXX=003
	0.2	XXX=002
Step	a [m]	XXX

6.0 to 100	±1%
0.6 to 5.9	+0.04
0.2 to 0.5	+0.02
a [m]	Tolerance

Ha-VIS EtherRail Cable,
4xAWG 22/7, Cat. 5, black

Type of cable

09480222011XXX

Part no.

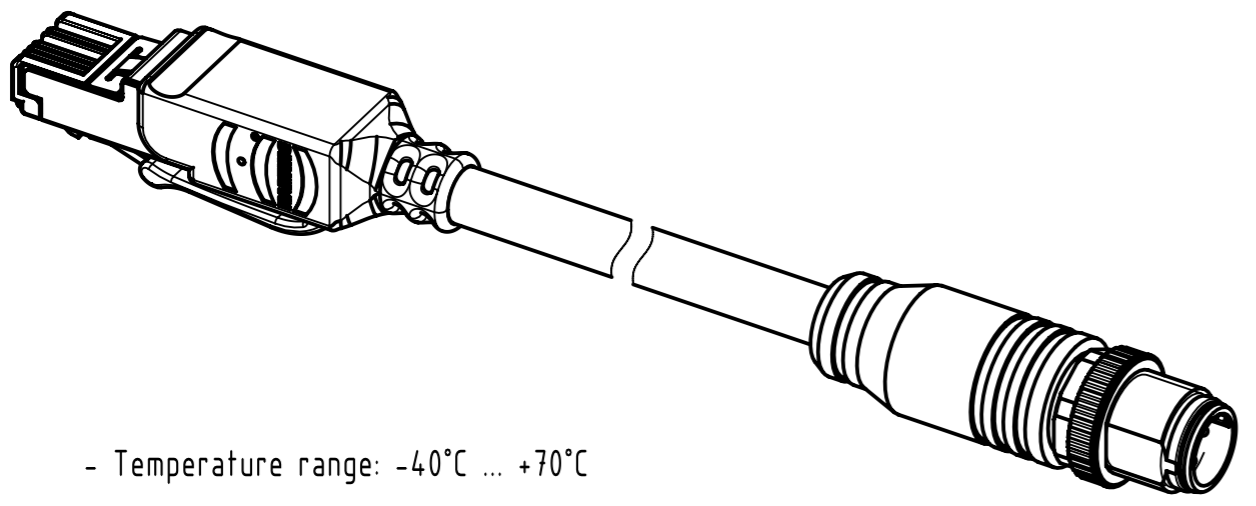

- Temperature range: -40°C ... +70°C

	All rights reserved	Created by STOCHECIC Stocheici	Inspected by 402676 Gross	Standardisation MUNTEANV Muntean	Date 2021-02-22	State Final Release
	Department HCS - RO	Title RJI M12 D-cod EtherRail Cable Assy		Doc-Key / ECM-Nr. 100542553/UGD/044/D 500000189773		
HARTING Customised Solutions D-32339 Espelkamp		Type TB	Number 09480222011XXX		Rev. D	Page 1/1