

CUP (pre-assembled)

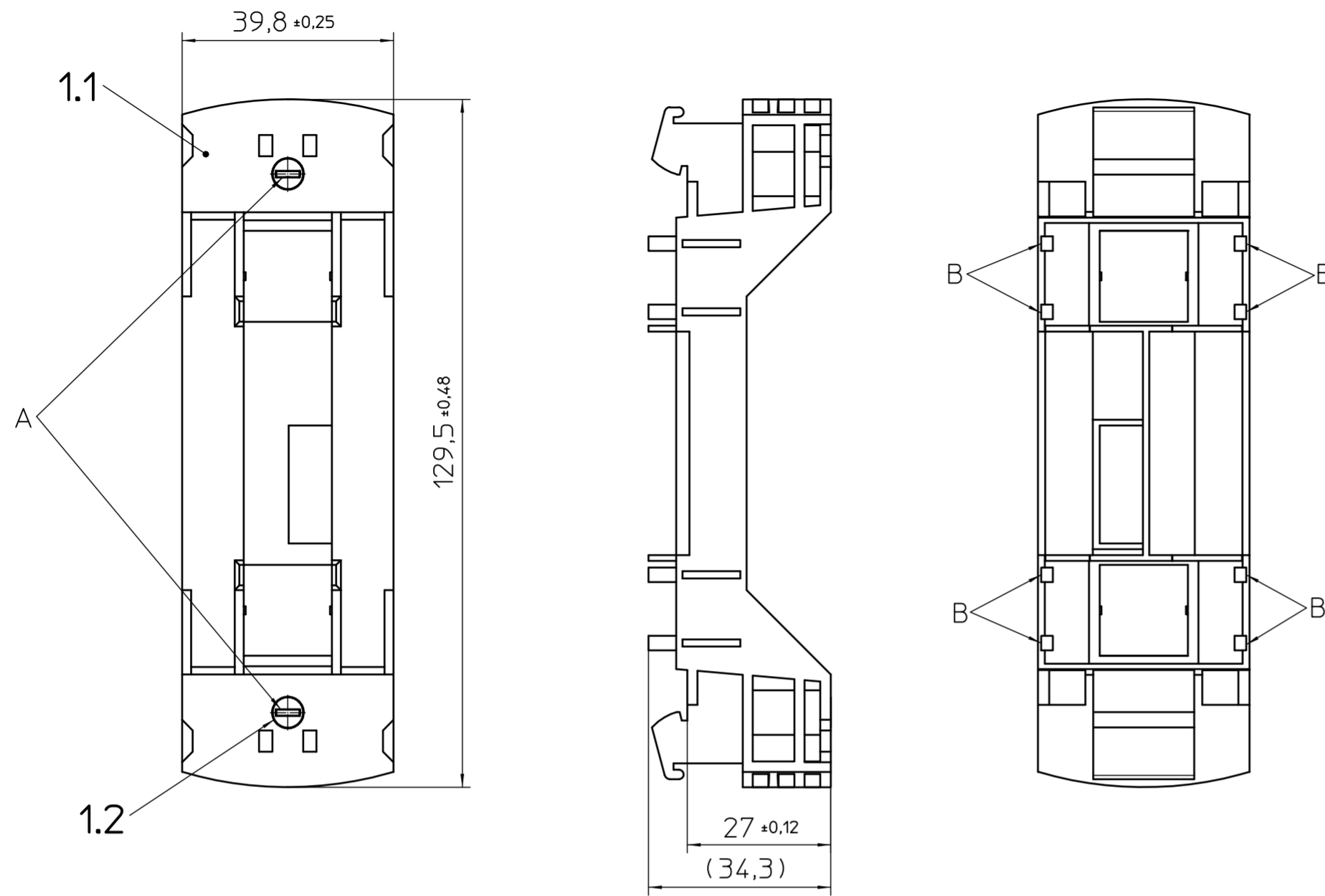

Assembly example: ME PLC EBT

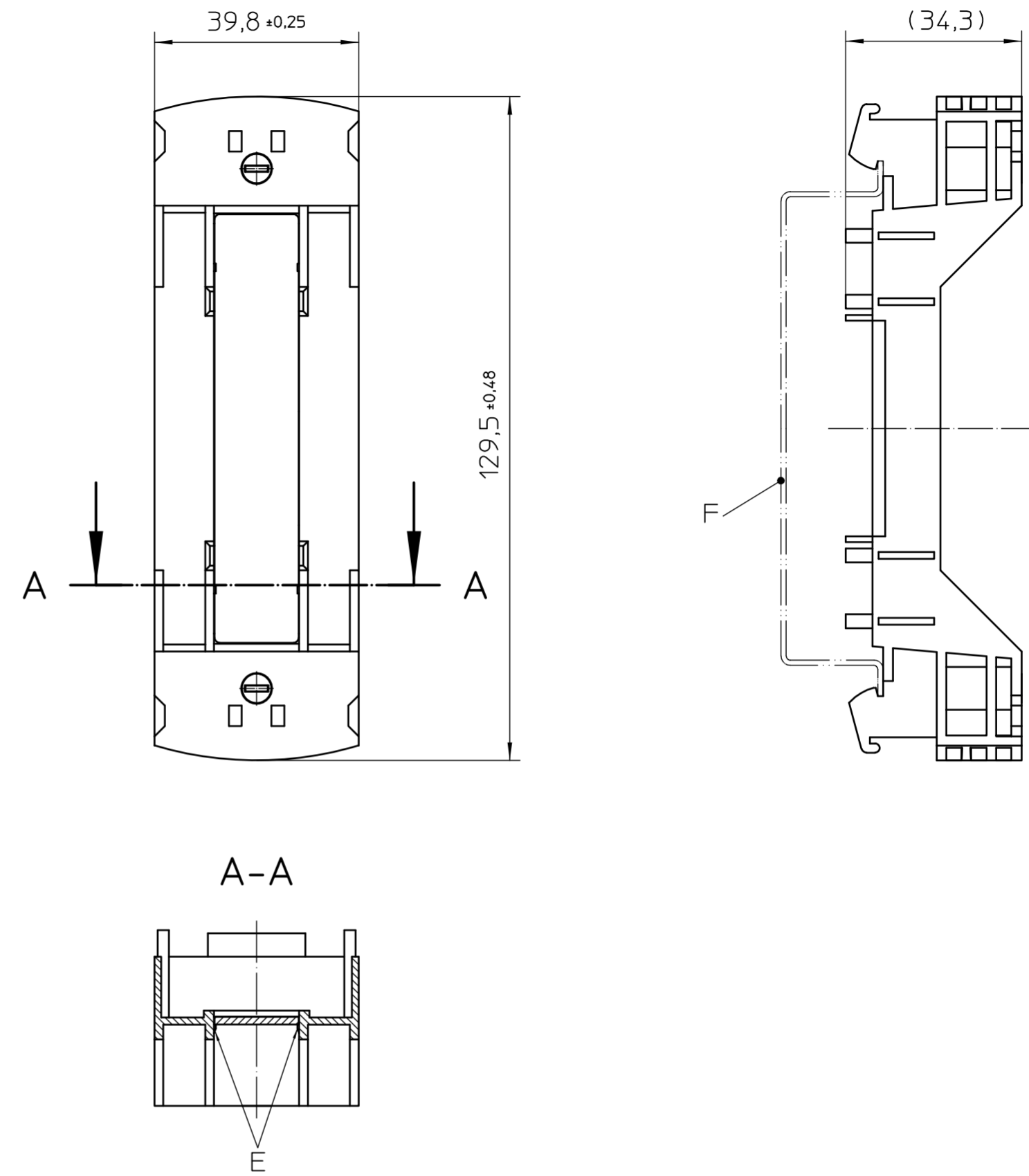

PLATE

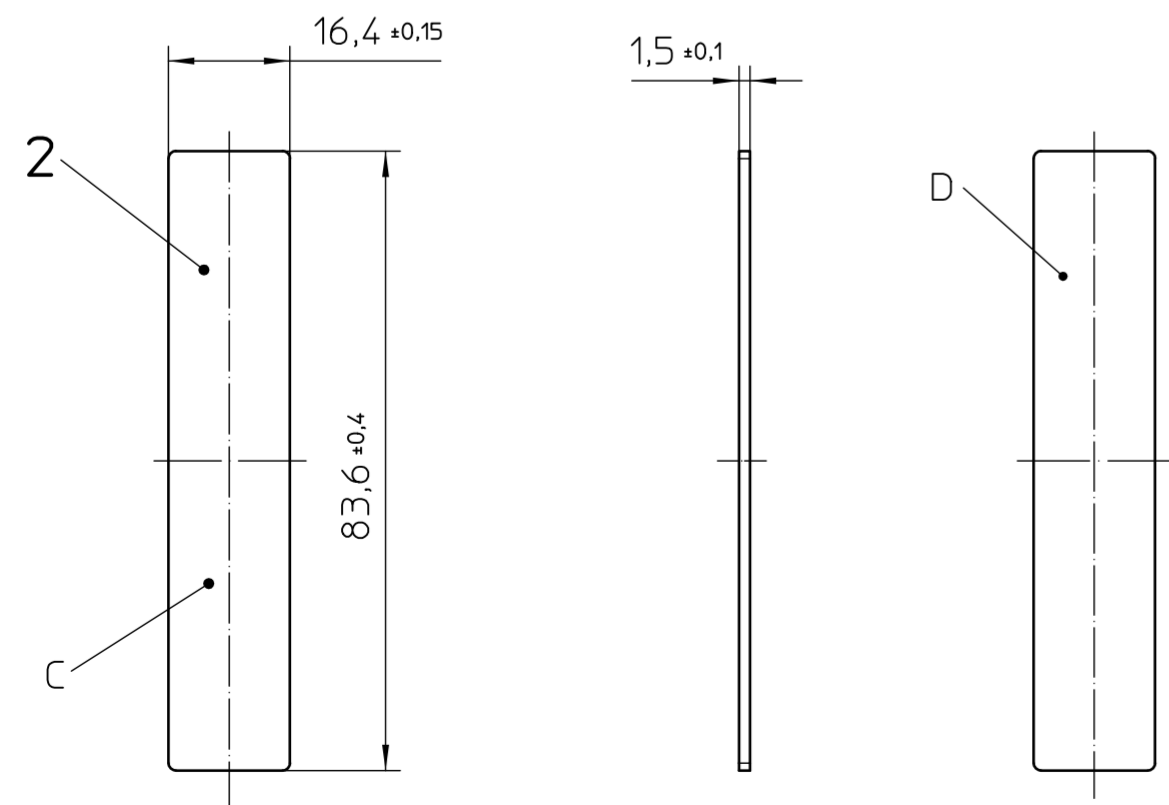

- Simplified representation
- Document excluded from change process
- Linear dimensions [mm]
- Tolerances apply in a normal climate according to DIN EN ISO 291-23/50-2.
- Web: www.phoenixcontact.com webcode: #0309

Additional Information:

- A. Slot for screwdriver 4x1mm
- B. Latching point between cup and bus chassis
- C. Exposed side
- D. Inner side
- E. Latching point between cup and plate
- F. Mounting rail: TH 105-20

KIT (not mounted)			
Pos.	QTY	Description	Material
1	1	CUP	PC
1.1		CUP	PC
1.2		SCREW	
2	1	PLATE	PC

	DIN A2	document-No. / RI 00934598 / 01	date 25.07.2017	scale 1:1
		ident.-No. 2201498	document-type TECDOC 2D_Productdrawing	
page 1 of 1	description ME PLC EBT GY7035			

Transfer or duplication of this document as well as the utilisation or communication of its content are not permitted unless express consent is granted. Violations give rise to claims for damages. All rights reserved in case of patent, utility model or design patent registrations.

Weitergabe sowie Vervielfältigung dieses Dokuments, Verwertung und Mitteilung seines Inhalts sind verboten, soweit nicht ausdrücklich gestattet. Zuwiderhandlungen verpflichten zu Schadensersatz. Alle Rechte für den Fall der Patent-, Gebrauchsmuster- oder Designeintragung vorbehalten.