

assembly notes see catalog
 crimp zone acc. to DIN EN 46235; indicator 8
 for cable: Forcepack Type F1017 (class 6 cable acc. to DIN EN 60228)
 wire gauge: 16mm²
 stripping length: 22mm

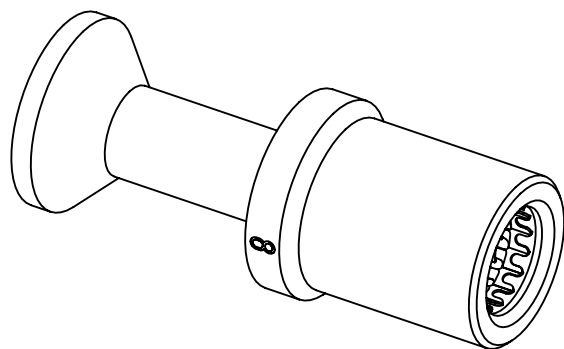

	All Dimensions in mm Original Size DIN A4	Scale 2:1		Free size tol.		Ref.	
		Created by HELLMANN		Inspected by NICHTERLEIN		Standardisation SAP_WFRT	
	All rights reserved Department EL PD	Date 2022-10-07		State Final Release		Doc-Key / ECM-Nr. 100840039/UGD/002/C 50000224.832	
		Title Han TC250 female contact 16mm ² (d=6.0mm)		Type TB		Number 09 11 000 6641	
HARTING D-32339 Espelkamp		Rev. C		Page 1/1			