

Produktdatenblatt

Art. Nr. 92.298.2063.7

Konfektionierte Leitung GST18i3KSB- 25H 20GN07

GST18i3 Anschlussleitung Buchse - freies Ende, Länge 2,0 m, 3-polig, Kodierung nach Kundenwunsch mit PE, 20 A, Kodierfarbe maigrün, Zugentlastungsfarbe schwarz, Leitungsfarbe schwarz, Leiterquerschnitt 2,5 mm², Kabeltyp H05Z1Z1-F, Brandklasse: Eca



Art. Nr.	92.298.2063.7
EAN	4049088279317
Bestelleinheit	25 Stück

Zulassungen
Technische Zeichnung

These Dimensionen sind die typischerweise (normal) zu liefernde Dimensionen. Abweichungen sind zulässig, wenn diese in den Zeichnungen angegeben sind.

These dimensions are the typical (normal) dimensions to be delivered. Deviations are permissible if they are indicated in the drawings.

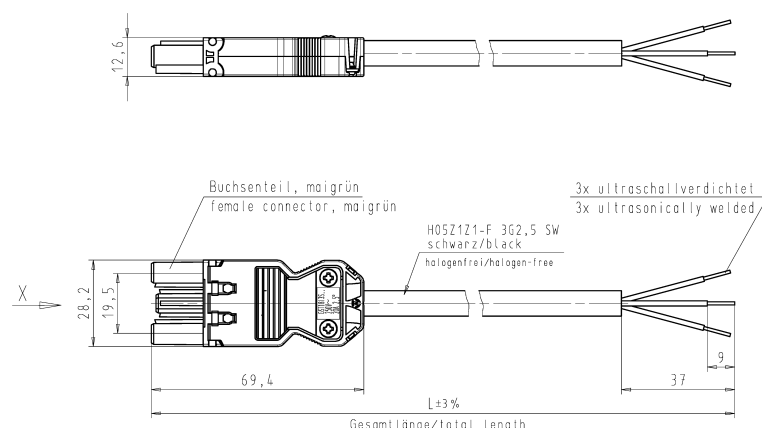

2/N = blau/blue
 ⊕ = grün-gelb / green-yellow
 1 = braun/brown

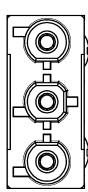

Teile-Nr. / part-no.	L	Beispiel (Farbe: maigrün) / example (colour: may green)	Typ / type
92.298.XX63.7	XX in dm-Schritten	92.298.1063.7 = 10dm/L = 1000mm	GST1813KSB- 25H 10GN07
U2.298.XX63.7	XX in m-Schritten	U2.298.1263.7 = 12 m/L=12000mm	GST1813KSB- 25H X12GN07

Weitere Daten siehe KATALOG oder eCatalog. / Additional data see CATALOG or eCatalog. www.wieland-electric.com eshop.wieland-electric.com

Tolerierung Size ISO 14045(2)/Tolerance system Size ISO 14045(2). (This ISO-standard describes the envelope principle. According to the envelope principle the deviations of form and parallelism are limited by the size tolerances). (Tolerances according to DIN EN ISO 14045(2) and DIN EN ISO 14045(2) are not applicable. Conforms with Wieland document WM 5202.014. If not at production, principle the deviations of form and parallelism are limited by the size tolerances). (Tolerierung: -) First issue: -

Freitoleranz nach / General tolerances	ISO - Zeichnung, keine manuellen Änderungen / ISO - drawing, no manual modifications allowed	1 Teilvermessung: - / First issue: -	Blatt: 1 / of: 1
Werkstoff/Material	Z01.c	Tag/Datum / Name	Zeichnung Nr./Drawing No.
Gezeichnet / Drawn	21.08.	Dütsch, T.	92.298.0263.7 01K
Geprüft / Checked	-	-	
Freigegeben / Released	-	-	Made in mm/Dimensions are in mm
Vol.	nr 011/Ser1.	Erstz. für/Replacement for: -	
Index	Datum / Date	Typ	Benennung/Título
Änderung/Revision		GST1813	PRE-ASSEMBLED CABLE KONFEKTLEITUNG

Buchse-fr., Ende Schraubausführung/screw connection
250V AC 20A 2,5gmm halogen-free

922980263701K_2 CADW3027 Duetsch | 2014-08-22T08:48:48 | 21.000
3
4
5
6
DU-YEE-01/14 -