

Transfer or duplication of this document as well as the utilisation or communication of its content are not permitted unless express consent is granted. Violations give rise to claims for damages. All rights reserved in case of patent, utility model or design patent registrations. Tolerance specifications do not include clearances inherent in the design.

Weitergabe sowie Vervielfältigung dieses Dokuments, Verwertung und Mitteilung seines Inhalts sind verboten, soweit nicht ausdrücklich gestattet. Zuwiderhandlungen verpflichten zu Schadensersatz. Alle Rechte für den Fall der Patent-, Gebrauchsmuster- oder Designeintragung vorbehalten. Bauartbedingtes Spiel ist in den Toleranzangaben nicht berücksichtigt.

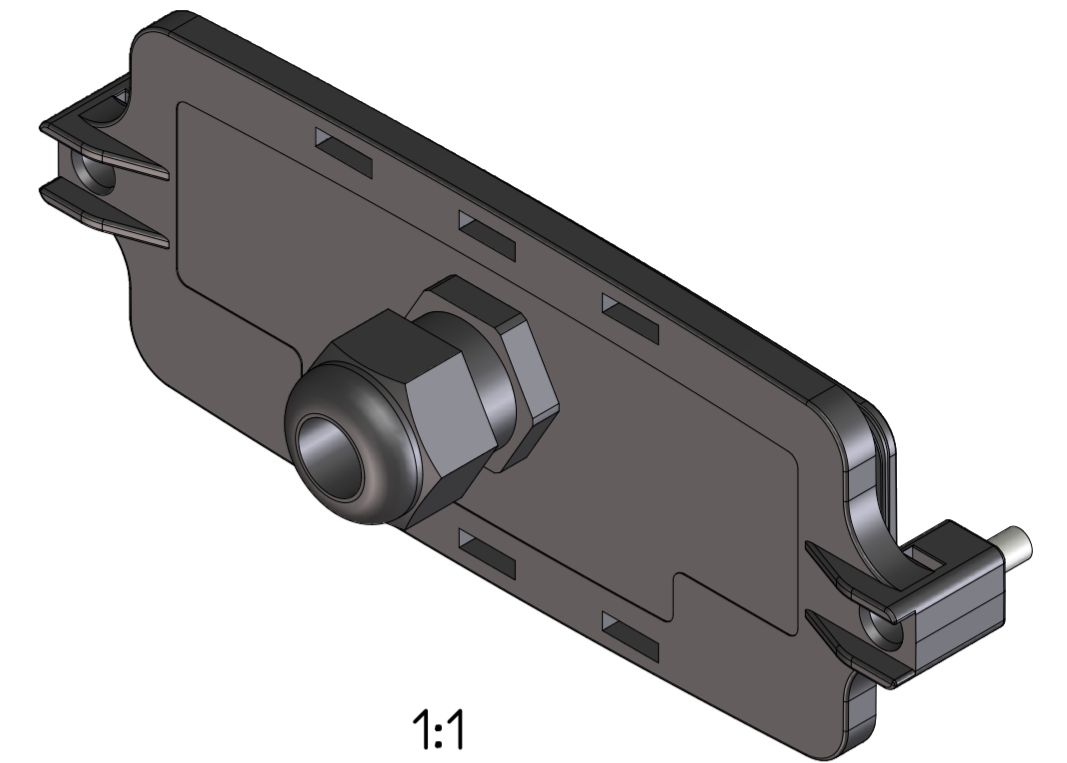

Application example

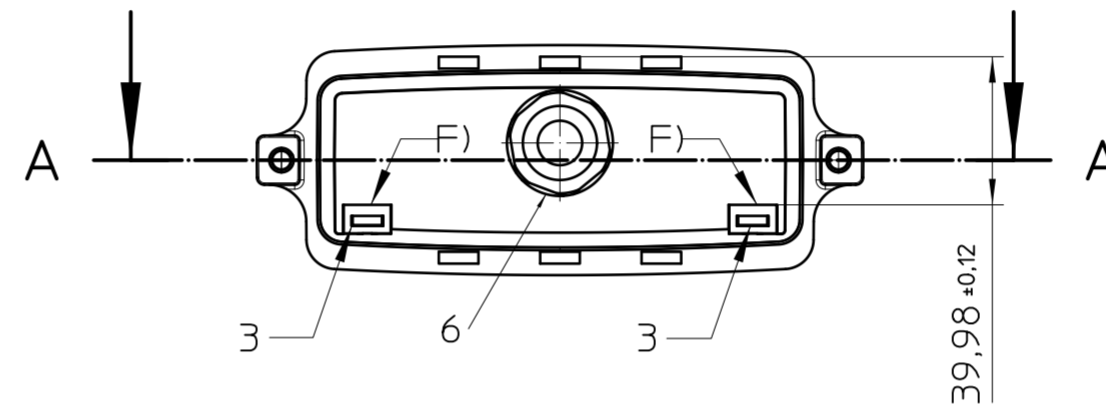
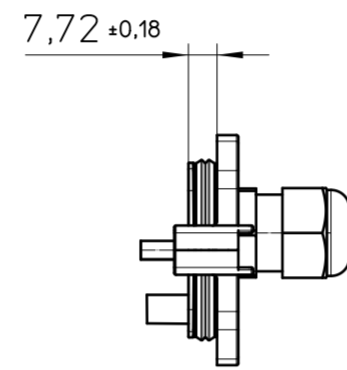
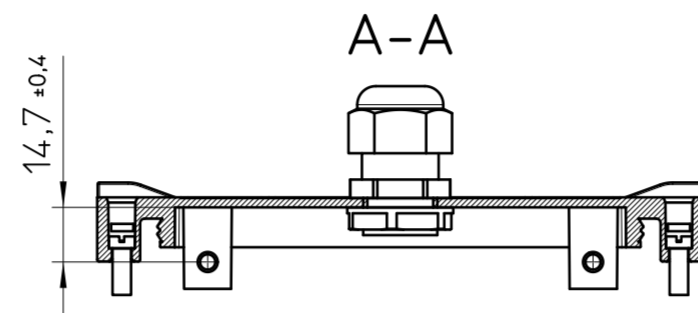
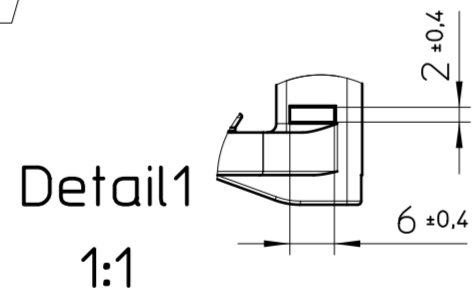
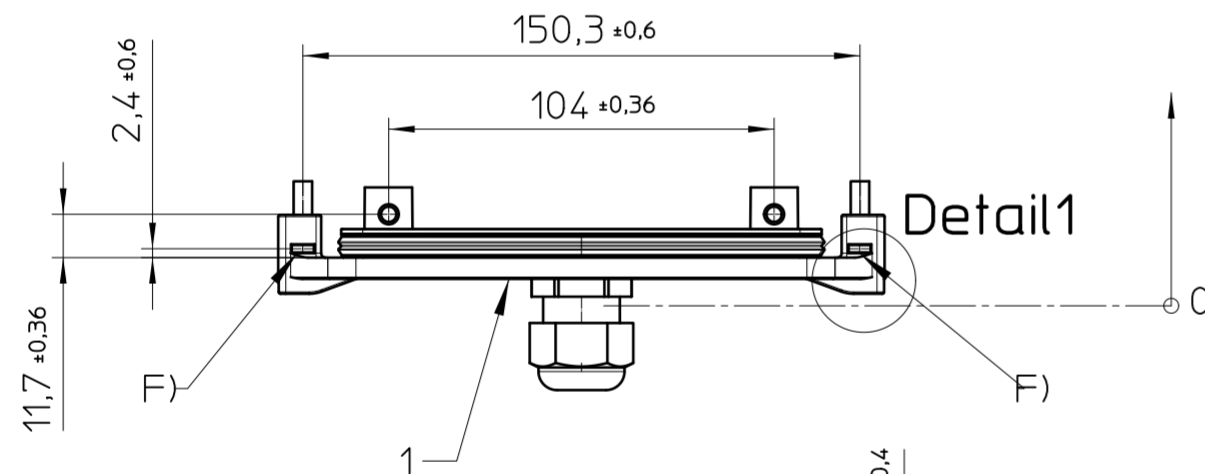
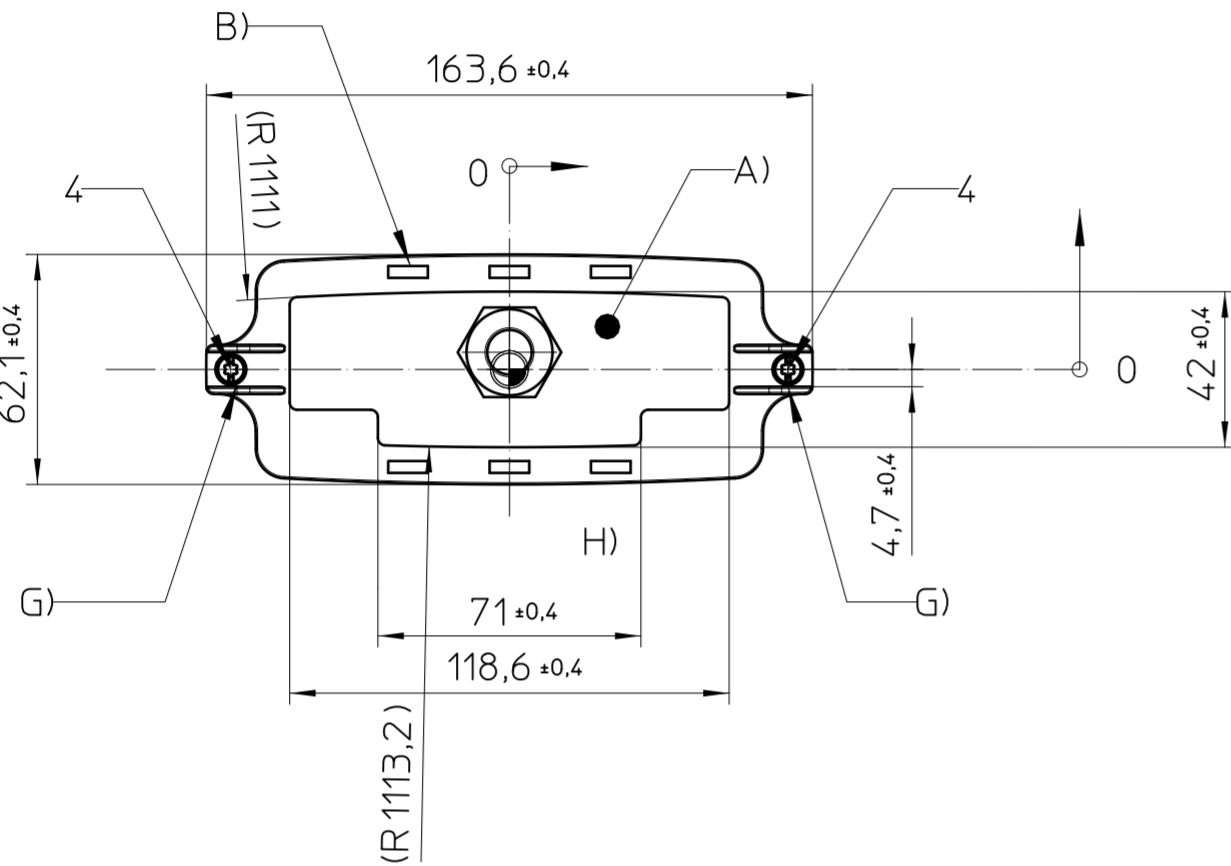
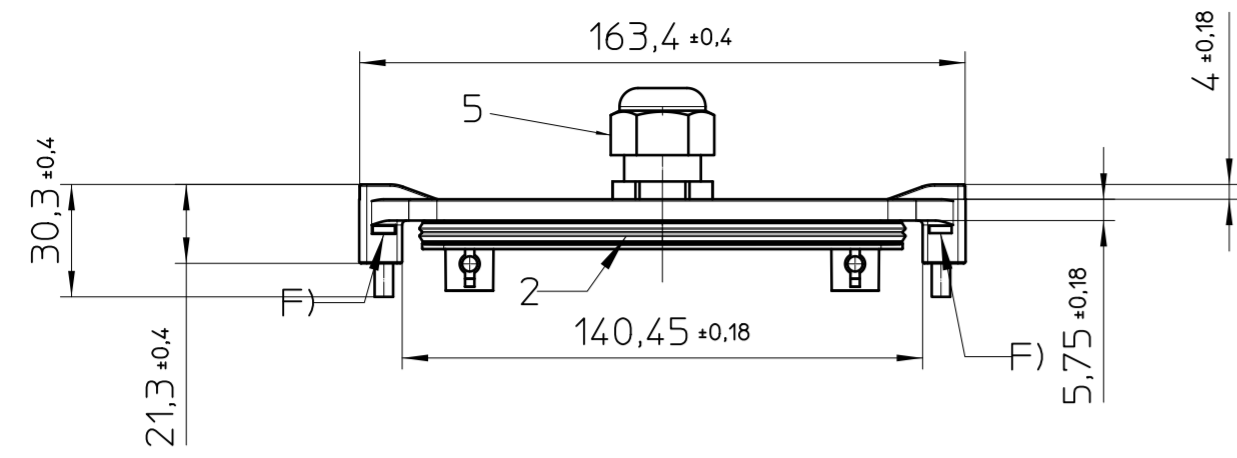
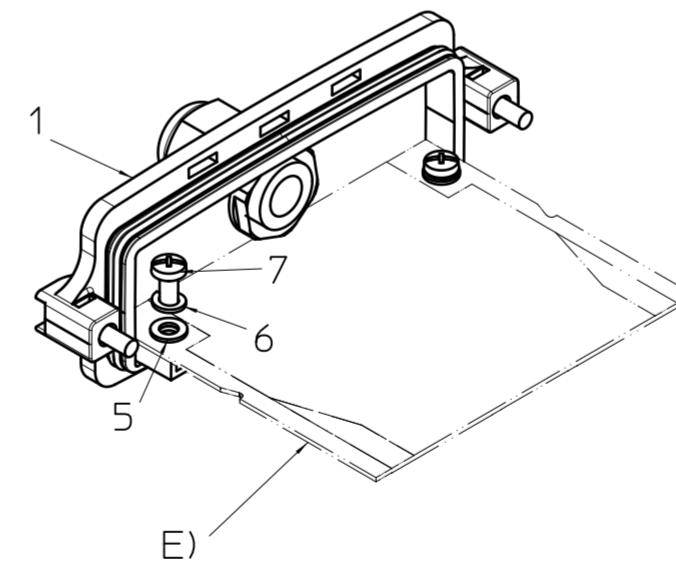

GENERAL INFORMATION:

- SIMPLIFIED REPRESENTATION, EXEMPLARY SHOWN IN BLACK
- DOCUMENT EXCLUDED FROM CHANGE PROCESS
- LINEAR DIMENSIONS (MM)
- WEB: WWW.PHOENIXCONTACT.COM WEBCODE: #0857

ADDITIONAL INFORMATION:

- A) LABEL / MILLING / PRINT AREA
- B) ENCLOSURE ALIGNMENT LUG SLOTS (6X) FOR ECS-B-122X169-L...
- C) TAMPER PROOF FEATURE
- D) PCB MOUNTING AREA
- E) CUSTOMER SUPPLIED PCB
- F) TAMPER PROOF FEATURE
- G) SCREW RETENTION FEATURE
- H) CABLE GLAND

WORKPIECE ZERO POINT FOR MECHANICAL PROCESSING

CUSTOMER ASSEMBLED COMPONENTS

Pos.	QTY	description	material
7	2	FLAT WASHER 5MM	Zn STL
8	2	SPLIT LOCK WASHER 5MM	Zn STL
9	2	PHILLIPS SCREW M5X12	Zn STL

Pos.	QTY	description	material
1	1	ECS FACEPLATE	PC
2	1	FACEPLATE SEAL	SI
3	2	SQUARE NUTS	ZN STL
4	2	M5 SCREWS	ZN STL
5	1	CABLE GLAND	PA
6	1	CABLE GLAND NUT	PA

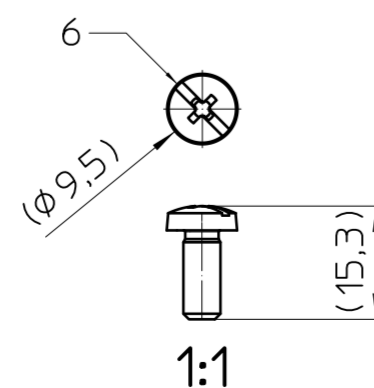
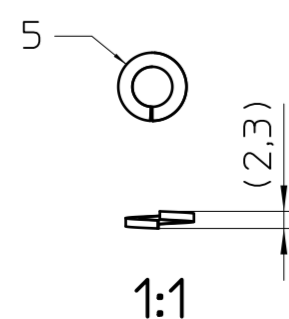
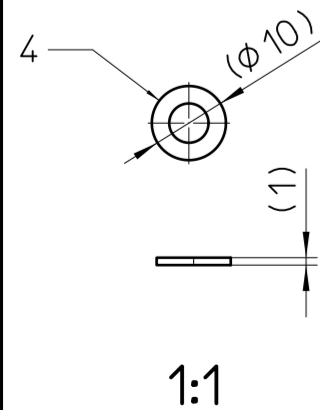

DIN A2
 PHOENIX CONTACT
 document-no. / ri: 01050804 / 02 | article-no.: 1050380
 date: 19.01.2026 | document-type: TECDOC_2D_Productdrawing
 description: ECS-P-122X169-S-UV-CG GY
 scale: 1:2
 page 1 of 1